

TOOMAX[®]

STORER PLUS 3XL

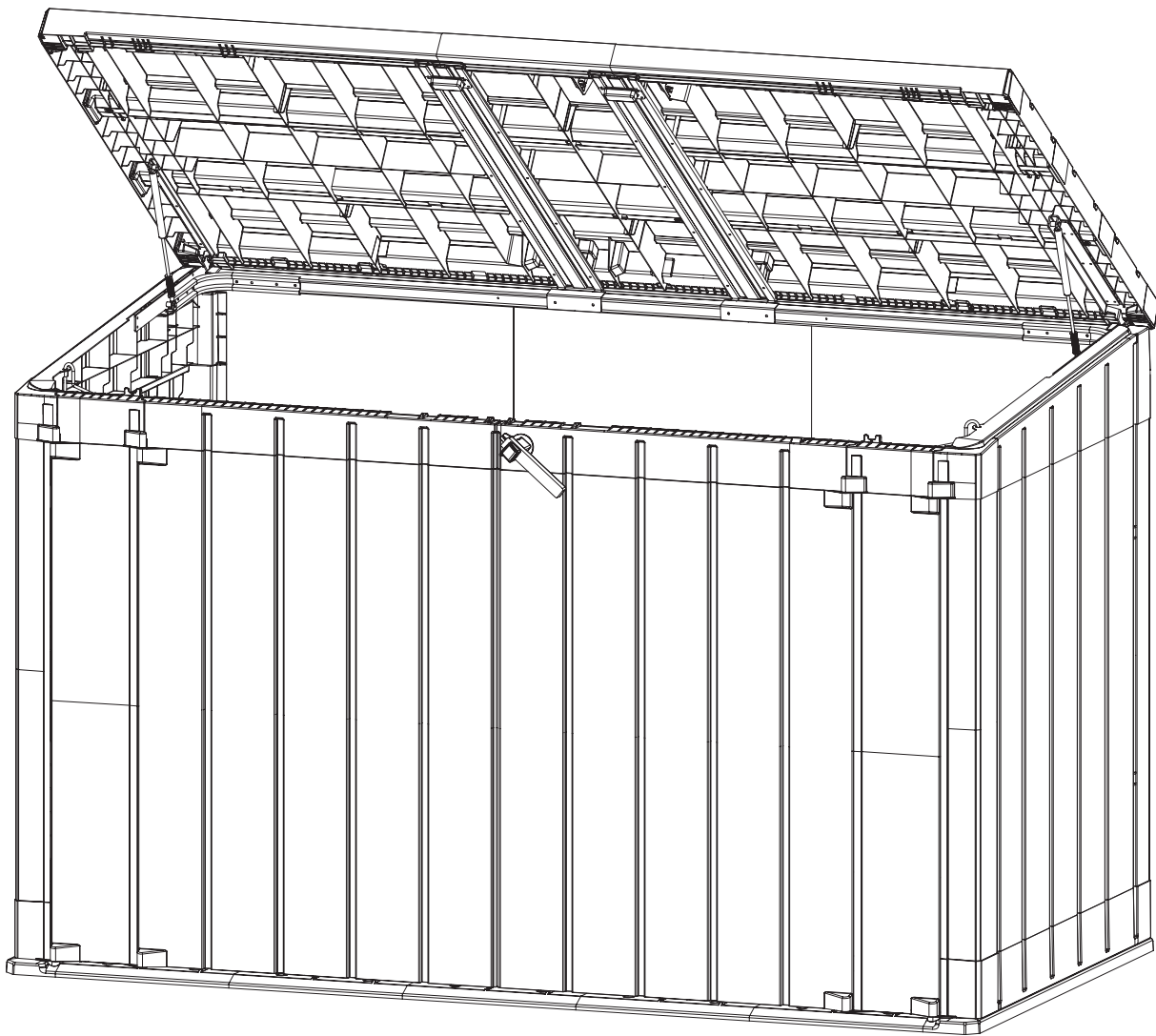

Art. 109 cm 216x109x140h | in 85x42,9x55,1h



(IT) IMPORTANTE. CONSERVARE PER FUTURE REFERENZE: LEGGERE ATTENTAMENTE!

(EN) IMPORTANT. RETAIN FOR FUTURE REFERENCE: READ CAREFULLY!

(FR) IMPORTANT. A CONSERVER POUR CONSULTATION ULTERIEURE: A LIRE ATTENTIVEMENT!

(ES) IMPORTANTE. CONSERVAR PARA CONSULTA ULTERIOR. LEER ATENTAMENTE!

(DE) WICHTIG. FÜR SPÄTERE NACHSCHLAGZWECKE AUFBEWAHREN. SORGFÄLTIG LESEN!

PRIMA DI INIZIARE L'ASSEMBLAGGIO / BEFORE STARTING ASSEMBLY / ANTES DE EMPEZAR EL MONTAJE / VOR DER MONTAGE / AVANT D'ENTAMER LE MONTAGE

IT:

1. In caso di pezzi mancanti o danneggiati all'interno del cartone, rivolgersi al punto vendita presentando la prova di acquisto. Indicare sempre il codice dei pezzi mancanti o danneggiati, indicati alla sezione "ISTRUZIONI DI MONTAGGIO" di questo manuale.

2. Dopo aver livellato la superficie del terreno con appositi attrezzi da lavoro, si raccomanda di fissare il prodotto ancorandolo al suolo tramite i fori oppure al muro tramite viti adeguate (le viti non sono incluse).

3. La confezione contiene alcuni componenti metallici taglienti o appuntiti; si raccomanda di indossare guanti da lavoro durante il montaggio del prodotto.

4. A causa di variazioni nella produzione, la dimensione effettiva del prodotto assemblato può variare leggermente dalle dimensioni menzionate.

EN:

- 1. If parts are missing or damaged, please contact your local dealer accompanied by the proof of purchase. Remember to indicate the code of missing or damaged parts always referring to this manual.*
- 2. After levelling the surface or onto the wall, it is mandatory to anchor the product to the ground by drilling holes in the product floor after levelling the surface or onto the wall, using proper screws (screws are not provided).*
- 3. The pack may contain some metallic sharp parts. Please be careful when handling these components. Always wear work gloves.*
- 4. Due to variations, the actual assembled size may vary slightly from the specified dimensions.*

ES:

- 1. Si dentro de la caja faltan piezas, o están piezas dañadas, póngase en contacto con el punto de venta, llevando con sigo la prueba de compra. Siempre hay que indicar los códigos de las piezas faltantes o dañadas, como enumerados en la sección "INSTRUCCIONES DE MONTAJE" de este manual.*
- 2. Después de haber nivelado la superficie del suelo con unas herramientas adecuadas, se recomienda fijar el producto anclándolo al suelo mediante los agujeros o a la pared con tornillos adecuados (los tornillos no están incluidos).*
- 3. La caja contiene algunos componentes metálicos afilados o puntiagudos; se recomienda utilizar guantes de trabajo para el montaje del producto.*
- 4. Debido a variaciones de producción, las dimensiones reales del producto montado pueden diferenciarse ligeramente de las dimensiones declaradas.*

DE:

- 1. Bei fehlenden oder beschädigten Teilen im Karton wenden Sie sich bitte an die Verkaufsstelle und legen den Kaufbeleg vor. Stets die Artikelnummer der fehlenden oder beschädigten Teile, die im Abschnitt "MONTAGE-ANLEITUNG" dieses Handbuchs wiedergegeben sind, angeben.*
- 2. Nach der Nivellierung der Bodenfläche mit geeignetem Arbeitsgerät empfiehlt es sich, das Produkt durch Verankerung im Boden mit Löchern oder an der Wand mit geeigneten Schrauben (nicht im Lieferumfang enthalten) zu befestigen.*
- 3. Die Packung enthält einige scharfe oder spitze Metallteile. Während der Montage des Produkts ist es ratsam, Arbeitshandschuhe zu tragen.*
- 4. Aufgrund von Änderungen in der Produktion können die effektiven Maße des montierten Produkts leicht von den erwähnten Maßen abweichen.*

FR:

- 1. En cas de pièces manquantes ou endommagées dans le carton, s'adresser au point de vente avec une preuve d'achat. Toujours indiquer le code des pièces manquantes ou endommagées, présent dans la section « INSTRUCTIONS DE MONTAGE » de ce manuel.*
- 2. Après avoir nivelé le terrain avec des outils de travail appropriés, il est recommandé de fixer le produit en l'ancrant au sol par les trous ou au mur par des vis adéquates (les vis ne sont pas incluses).*
- 3. La boîte contient des composants métalliques tranchants ou pointus ; il est recommandé de porter des gants de travail lors du montage du produit.*
- 4. A cause des variations dans la production, les dimensions réelles du produit monté peuvent varier légèrement par rapport aux dimensions indiquées.*

ATTREZZATURA OCCORRENTE PER IL MONTAGGIO / REQUIRED TOOLS / HERRAMIENTAS NECESARIAS PARA EL MONTAJE / FÜR DIE MONTAGE BENÖTIGTE GERÄTE/ OUTILS NECESSAIRES POUR LE MONTAGE

IT: Attrezzatura non inclusa! **EN:** Tools not included! **ES:** Las Herramientas no están incluidas!

DE: Geräte sind nicht inbegriffen! **FR:** Outils non inclus!

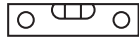

**GARANZIA LIMITATA DI 2 ANNI / 2 YEAR LIMITED WARRANTY / GARANTÍA LIMITADA DE 2 AÑOS
ZWEI-JÄHRIGE GARANTIE / GARANTIE LIMITEE DE 2 ANS**

IT: L'intera gamma dei prodotti viene prodotta con materiali di qualità e sotto controllo rigoroso. Qualora si presentasse un problema, rivolgersi al punto vendita presso cui è stato acquistato il prodotto.

Plastmeccanica S.p.A. sottopone i propri prodotti a test di resistenza e di stabilità ed è pronta a sostituire, a propria discrezione, qualsiasi prodotto o parti di esso qualora sia presente un difetto strutturale o produttivo per un periodo di 2 anni a partire dalla data di acquisto. Il periodo della garanzia inizia a partire dalla data di acquisto, quindi è necessario conservare la prova di acquisto da poter presentare su richiesta.

Dopo aver presentato un reclamo, il periodo di garanzia continuerà ad essere calcolato e resterà valido fino alla data della sua scadenza.

Sono esclusi dalla presente garanzia: danni causati da uso di forza, utilizzo non corretto o inappropriato, negligenza, uso commerciale o diverso da quello personale o domestico, danni derivanti da alterazione, pittura o assemblaggio non eseguito in conformità alle istruzioni di montaggio, danni causati dagli effetti di condizioni meteorologiche eccezionali (inclusi ma non limitati a temporali).

Plastmeccanica S.p.A. non si riterrà responsabile di eventuali danni causati ai beni riposti all'interno del prodotto.

EN: The full range of products is made with high quality materials and under strict controls. In case a problem should occur, please address your claim to the dealer where you purchased the product.

Plastmeccanica S.p.A. always tests its products for durability and stability and shall replace, at its discretion, any product or part which fails due to structural defect or faulty workmanship for a 2-year period from the date of purchase. The warranty period shall begin on the date of purchase; you should therefore keep the dated receipt to present upon request.

After a claim has been settled, the warranty period will continue to be counted and shall terminate upon its expiry date.

Damages caused by use of force, incorrect handling, inappropriate use, neglect, commercial use or use other than for personal or domestic purposes, damages resulting from alteration, painting or assembly not in accordance with the instruction manual and damages caused as a result of overload are excluded from warranty. In addition, the warranty excludes any damage coming from exceptional weather condition effects (including but not limited to storms).

Lastly, Plastmeccanica S.p.A shall not be responsible for any damage to goods stored inside the product.

ES: Los baúles de la colección están fabricados con materiales de calidad bajo un estricto proceso de control. En caso de problemas, póngase en contacto con el punto de venta donde ha adquirido el producto. El periodo de garantía empieza desde la fecha de adquisición, por lo tanto le rogamos conservar una prueba de adquisición con fecha que tendrá que presentar a petición. Plastmeccanica S.p.A. somete sus productos a pruebas de resistencia y estabilidad y está dispuesta a sustituir a su discreción cualquier producto o parte de ello en presencia de defectos estructurales o defectos de producción por un periodo de 2 años desde la fecha de adquisición. Los daños ocasionados por uso de la fuerza, manipulación incorrecta, uso inapropiado, negligencia, uso comercial o uso diferente del uso personal o doméstico; los daños derivados de modificación, pintura o montaje no realizados en conformidad con el manual de instrucciones y los daños ocasionados por la sobrecarga del producto no están cubiertos por esta garantía. Además, la garantía no se aplica a daños ocasionados por los efectos de condiciones meteorológicas extraordinarias (incluso, sin limitaciones, tormentas). Tras la resolución de una reclamación, el periodo de garantía continuará calculándose y quedará válido hasta la fecha de caducación. Plastmeccanica S.p.A. no será responsable de daños ocasionados a los bienes colocados en el interior del producto.

DE: Die gesamte Palette der Kissenboxen wird unter einer strengen Kontrolle aus hochwertigen Materialien hergestellt. Sollte ein Problem auftreten, richten Sie Ihre Reklamation an Ihren Händler vor Ort. Die Garantiezeit läuft ab dem Kaufdatum. Sie werden somit gebeten, einen datierten Kaufbeleg aufzubewahren, um ihn auf Verlangen vorlegen zu können. Die Fa.

Plastmeccanica S.p.A. unterzieht ihre Produkte Haltbarkeits- und Stabilitätstests und ist nach ihrem Ermessen bereit, in dem Zeitraum von 2 Jahren ab Kaufdatum jedes Produkt oder Teile davon zu ersetzen, sollte ein Struktur- oder Produktionsfehler bestehen. Die durch Gewaltanwendung, falscher Handhabung oder unangemessenen Gebrauch, Vernachlässigung, gewerblichen Gebrauch oder anderen als den persönlichen oder Hausgebrauch bedingten Schäden, die aus Veränderung, Anstrich oder nicht mit dem Anleitungshandbuch konformer Montage herrührenden Schäden sowie die von den Auswirkungen der Überladung des Produkts verursachten Schäden sind von der vorliegenden Garantie ausgenommen. Außerdem wird die Garantie nicht auf Schäden, die durch Auswirkungen von außergewöhnlichen Wetterbedingungen (einschließlich aber nicht nur darauf beschränkt Unwetter) verursacht werden, angewandt. Nach der Einreichung einer Reklamation läuft die Garantie weiter und erlischt an ihrem Verfallsdatum. Die Fa. Plastmeccanica S.p.A. haftet nicht für eventuelle Schäden an in der Box verstauten Gütern.

FR : Toute la gamme de coffres est réalisée avec de matériaux de qualité et sous un contrôle rigoureux. En cas de problèmes, s'adresser au point de vente où le produit a été acheté. La période de garantie commence à partir de la date d'achat, donc veuillez conserver une preuve d'achat datée à présenter sur demande. Plastmeccanica S.p.A. teste la durabilité et la stabilité de ses Produits et elle est prête, à son entière discrétion, à remplacer, pendant un délai de 2 ans à partir de la date d'achat, tout Produit ou une partie du Produit au cas où un défaut structurel ou de production serait présent. Tout dommage causé par l'usage de la force, un emploi non correct ou inadéquat, négligence, un emploi commercial ou différent de l'usage personnel ou domestique ; tout dommage résultant d'altération, peinture ou montage effectué non en conformité avec le manuel d'instructions ; tout dommage causé par la surcharge du Produit est exclu de cette garantie. Outre à cela, la garantie ne couvre pas les dommages causés par les effets des conditions météorologiques exceptionnelles (inclus, sans limitation, les orages). Après avoir déposé une réclamation, la période de garantie continuera à être calculée et sera valable jusqu'à la date de son échéance. Plastmeccanica S.p.A ne sera pas responsable de tout dommage causé aux biens stockés dans le Produit.

MANUTENZIONE E SICUREZZA / CARE AND SAFETY / MANTENIMIENTO Y SEGURIDAD / INSTANDHALTUNG UND SICHERHEITDE / ENTRETIEN ET SECURITE

IT:

- Il prodotto è destinato esclusivamente a contenere oggetti; non è stato progettato per essere utilizzato come abitazione.
- È fondamentale assemblare tutte le parti seguendo accuratamente le istruzioni nella sequenza indicata, senza saltare alcun passaggio e con l'ausilio degli attrezzi indicati. Posizionare il prodotto su una superficie piana.
- Per la scelta del luogo di posizionamento tenere conto della direzione del vento, che può danneggiare il prodotto, in modo particolare le ante. Quando il prodotto non è in uso, tenere il prodotto chiuso per evitare danni.
- Durante il montaggio, indossare sempre guanti da lavoro e prestare attenzione alle parti taglienti o appuntite.
- Al termine del montaggio, smaltire gli imballaggi secondo la vigente normativa sulla raccolta dei rifiuti.
- Temperatura di esercizio: -5/+40° C
- Il prodotto non può essere usato per trasportare cose. Svuotare il prodotto prima di spostarlo.
- Evitare di eseguire il montaggio durante le giornate ventose e/o piovose.
- Pulire con acqua e saponi neutri, non aggressivi. Non usare spazzole dure né detergenti abrasivi. Evitare detergenti a base di oli e acetoni.
- Dopo la pioggia, asciugare sempre il prodotto con un panno asciutto.
- Evitare di urtare il prodotto con oggetti che potrebbero danneggiarlo.
- Controllare periodicamente che il prodotto sia stabile e sicuro.
- Non riporre sostanze chimiche infiammabili o corrosive.
- Non riporre oggetti caldi (ad esempio, grill o altre attrezzature incandescenti).
- Non idoneo per riporre alimenti.
- In caso di incendio, non usare l'acqua per spegnere il fuoco sugli oggetti in polipropilene.
- Non salire né sedersi sul coperchio.
- Non chiudere persone e/o animali all'interno del prodotto.
- Si raccomanda di fare attenzione alla chiusura delle ante, specialmente in presenza di bambini.
- Questo prodotto non è un giocattolo. Non permettere ai bambini di entrare all'interno.
- Conservare il presente manuale per future referenze.
- A fine vita, smaltire il prodotto secondo la vigente normativa sulla raccolta dei rifiuti.
- Consultare le autorità locali per verificare se sono necessari dei permessi per assemblare il prodotto.

EN:

- *This product is intended for storage use only. It is not designed to be used as habitation.*
- *It is crucial to assemble all the parts according to the instructions using tools listed in the manual. Do not omit any step. Place the product on a flat surface.*
- *Take into consideration the wind direction when selecting the placement of the product. In any case, reduce the exposure to the wind as much as possible. Keep doors closed and locked when the product is not in use to prevent such damage.*
- *Always wear work gloves and be careful when handling sharp or pointed parts.*
- *After installation, dispose of packaging in accordance with the local regulations.*
- *Working temperature: -5/+40° C.*
- *Not designed to carry items. Empty before moving.*
- *Do not attempt assembly on windy or cold days.*
- *Wash with water and mild detergent solution to avoid any damage to the plastic surface. Avoid using oil or acetone-based cleaners. Do not use stiff brushes or abrasive cleaners.*
- *After the rain, wipe with dry cloth.*
- *Do not hit the product with blunt objects.*
- *Periodically inspect the product is stable and safe.*
- *Not suitable for storing flammable or corrosive substances.*
- *Never store hot items in the box (such as recently used grills, blowtorches, irons, etc.).*
- *Not suitable for storing foods.*
- *In case of fire, do not attempt to extinguish burning polypropylene with water.*
- *Do not shut people or animals in the product.*
- *Be careful when closing the doors to avoid getting stuck with your hands, especially in the presence of children.*
- *The product is not a toy. To prevent risk of suffocation, do not allow children to play inside the product.*
- *Keep the manual for future reference.*
- *At the end of its useful life, dispose of the product in accordance with the local regulations.*
- *Consult your local authorities to check if permits are required to erect the shed.*

ES:

- *El producto está destinado exclusivamente a contener objetos; no ha sido diseñado para ser utilizado como alojamiento.*
- *Es muy importante montar todas las piezas siguiendo estrictamente las instrucciones, sin saltarse ningún paso. Se aconseja colocar el producto sobre una superficie llana.*
- *Al elegir el lugar para colocarlo, tenga en cuenta la dirección del viento, que puede dañar el producto, especialmente las puertas. Cuando el producto no esté en uso, manténgalo cerrado para evitar roturas.*
- *Utilice gafas de protección y siga siempre las instrucciones del fabricante durante el uso de utensilios.*
- *Una vez completado el montaje, elimine el embalaje según la normativa vigente.*
- *Temperatura de uso: -5/+ 40 °C*
- *El producto no ha sido diseñado para el transporte de utensilios. Vacíe el baúl antes de moverlo.*
- *Evite montar el producto en días ventosos o lluviosos.*
- *Limpie el producto con un detergente no agresivo para evitar dañar las superficies de plástico. No utilice cepillos duros o detergentes abrasivos.*
- *En caso de lluvia, seque el producto con un trapo antes de abrirlo.*
- *No choque contra el baúl con objetos puntiagudos.*
- *Compruebe periódicamente que el producto sea estable y seguro.*
- *El producto no es apropiado para contener sustancias inflamables o corrosivas.*
- *No coloque objetos calientes en el producto (como, por ejemplo, una parrilla recién usada, un soplete de soldadura, una plancha, etc.)*
- *El producto no es apto para la conservación de alimentos.*
- *En caso de incendio, no utilice agua para apagar el fuego en presencia de objetos de polipropileno.*
- *No se suba ni se sienta sobre la tapa.*
- *No encierre a personas y/o animales en el interior del producto.*
- *Preste atención a las manos al momento de cerrar la tapa, sobretodo en presencia de niños.*
- *Este producto no es un juguete. Para prevenir el riesgo de asfixia, no permita a los niños jugar dentro del baúl.*
- *Conserve estas instrucciones.*
- *Al final de la vida del producto, elimínelo según la normativa vigente.*
- *Consulte a las autoridades locales para ver si se requieren permisos para ensamblar el producto.*

DE:

- Das Produkt ist nur zur Aufbewahrung von Gegenständen bestimmt; es ist nicht zur Verwendung als Personenunterkunft bestimmt.
- Es ist äußerst wichtig, alle Teile gemäß der Anleitung zusammenzubauen. Keinen Schritt überspringen. Das Produkt sollte auf einer flachen Oberfläche positioniert werden.
- Berücksichtigen Sie bei der Wahl des Standorts die Windrichtung, da starker Wind das Produkt, insbesondere die Türen, beschädigen kann. Wenn das Produkt nicht benutzt wird, halten Sie es geschlossen, um Brüche zu vermeiden.
- Tragen Sie stets eine Schutzhandschuhe und befolgen Sie immer die Herstelleranleitung für den Gebrauch von Werkzeugen.
- Nach erfolgter Montage die Verpackung gemäß der geltenden Richtlinie entsorgen.
- Gebrauchstemperatur: -5/+40 °C
- Der Behälter wurde nicht zur Beförderung von Gegenständen entworfen. Leeren Sie ihn vor dem Transport.
- Vermeiden Sie den Aufbau an windigen und/oder regnerischen Tagen.
- Das Produkt mit einem milden Reinigungsmittel säubern, um die Kunststoffoberflächen nicht zu beschädigen. Keine harten Bürsten oder Scheuermittel verwenden.
- Wischen Sie nach Regen die Box vor dem Öffnen mit einem Lappen ab.
- Stoßen Sie nicht mit stumpfen Gegenständen an die Box.
- Überprüfen Sie regelmäßig, ob das Produkt stabil und sicher ist.
- Nicht für die Lagerung von entzündbaren oder ätzenden Stoffen geeignet.
- Keine warmen Gegenstände (wie z. B. noch vor kurzem verwendete Grillroste, Lötlampen, Bügeleisen usw.) in die Box stellen.
- Nicht für die Aufbewahrung von Lebensmitteln geeignet.
- Bei Feuer kein Wasser zum Löschen von brennenden Polypropylen-Gegenständen verwenden.
- Klettern oder setzen Sie sich nicht auf der Abdeckung.
- Schließen Sie keine Personen und/oder Tiere in der Box ein.
- Passen Sie beim Schließen des Deckels auf, dass Sie keine Hände einklemmen, besonders wenn Kinder zugegen sind.
- Das Produkt ist kein Spielzeug. Um die Erstickungsgefahr zu vermeiden, erlauben Sie es den Kindern nicht, darin zu spielen.
- Die vorliegende Anleitung aufbewahren.
- Das Produkt am Ende ihrer Lebensdauer gemäß der geltenden Richtlinie entsorgen.
- Erkundigen Sie sich bei den örtlichen Behörden, ob für den Aufbau des Produkts eine Genehmigung erforderlich ist.

FR :

- Le produit est destiné exclusivement à contenir des objets ; il n'a pas été conçu pour être utilisé comme habitation.
- Il est fondamental d'assembler toutes les parties en suivant soigneusement les instructions. Ne pas sauter aucune étape. Il est conseillé de placer le produit sur une surface plane.
- Lors du choix du lieu de positionnement, tenir compte de la direction du vent, qui peut endommager le produit, en particulier les portes. Lorsque le produit n'est pas utilisé, le garder fermé pour éviter les bris.
- Porter des gants de sécurité et suivre toujours les instructions du producteur en cas d'emploi d'outils.
- A la fin du montage, jeter l'emballage selon les règlements en vigueur.
- Température d'utilisation : -5/+40 °C
- Le produit n'a pas été conçu pour le transport d'objets. Le vider avant de le déplacer.
- Éviter d'effectuer le montage pendant les journées venteuses et/ou pluvieuses.
- Nettoyer le produit à l'aide d'un détergent doux pour ne pas endommager les surfaces en plastique. Ne pas utiliser de brosses dures ou de détergents abrasifs.
- Après la pluie, essuyer le produit à l'aide d'un chiffon avant de l'ouvrir.
- Ne pas heurter le produit avec des objets contondants.
- Vérifier périodiquement que le produit est stable et sûr.
- Le produit ne convient pas pour le stockage de substances inflammables ou corrosives.
- Ne pas placer d'objets chauds dans le coffre (comme par exemple une grille pour barbecue utilisée récemment, une lampe à souder, un fer à repasser, etc.).
- Le produit ne convient pas pour le stockage de la nourriture.
- En cas d'incendie, ne pas utiliser d'eau pour éteindre le feu sur les objets en polypropylène.
- Ne pas grimper ni s'asseoir sur le couvercle.
- Ne pas renfermer de personnes ou d'animaux à l'intérieur du Produit.
- Faire attention aux mains lors de la fermeture du couvercle, spécialement au cas où des enfants seraient présents.
- Ce produit n'est pas un jouet. Pour prévenir tout risque d'étouffement, ne pas permettre aux enfants de jouer à l'intérieur du produit.
- Conserver ce document.
- A la fin de sa durée de vie utile, jeter le produit selon les règlements en vigueur.
- Consulter les autorités locales pour savoir si des autorisations sont nécessaires pour assembler le produit.

AVVERTENZE SULLE MOLLE A GAS / WARNINGS REGARDING GAS SPRINGS / ADVERTENCIAS SOBRE LOS RESORTES DE GAS / HINWEISE ZU DEN GASDRUCKFEDERN DER BOX / AVERTISSEMENT CONCERNAT LES RESSORTS A GAZ

IT:

- Non tentare di aprire, perforare o modificare.
- Non posizionare vicino a fonti di calore.
- Non danneggiare l'asta. Non deve essere intaccata da corpi contundenti o abrasivi o da eventuali sostanze chimiche corrosive, vernici, oli o simili.
- Non lubrificare l'asta.
- Non installare se visibilmente danneggiata.
- Non applicare forze laterali.

EN:

- *Do not try to open, pierce or modify.*
- *Do not place near heating sources.*
- *Do not damage the gas spring rod. It shall not be hit by blunt or abrasive objects or any corrosive substance, paint, oil or similar.*
- *Do not lubricate the gas spring rod.*
- *Do not assemble if clearly damaged.*
- *Do not apply lateral forces.*

ES:

- *No intente abrir, perforar o modificar los resortes de ninguna manera.*
- *No coloque los resortes sobre fuentes de calor.*
- *La varilla de los resortes no debe entrar en contacto con objetos contundentes o abrasivos o con sustancias químicas corrosivas, pintura, aceite o sustancias similares que pueden dañarla.*
- *No engrase la varilla de los resortes.*
- *No realice el montaje en presencia de daños evidentes.*
- *No aplique fuerzas laterales.*





DE:





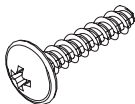

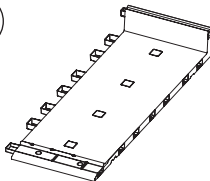
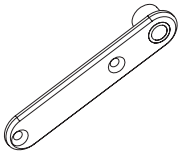
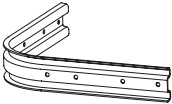
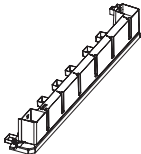
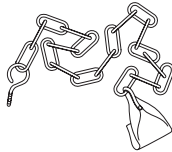
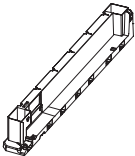
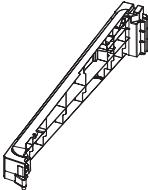
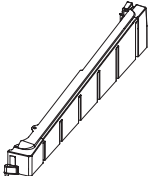
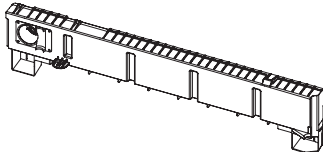
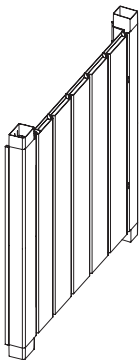
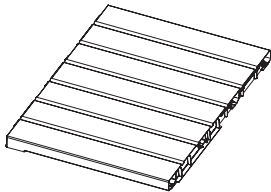
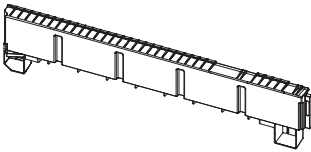
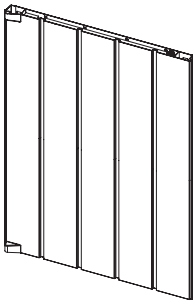

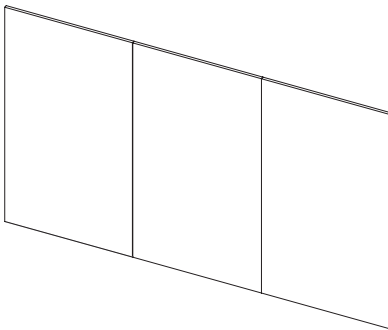

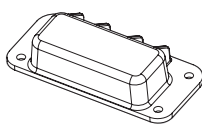
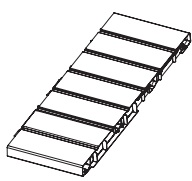

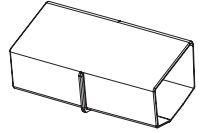
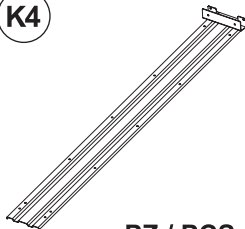
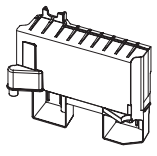
- *Versuchen Sie nicht sie zu öffnen, zu lochen oder sonst irgendwie zu verändern.*
- *Nicht über Wärmequellen positionieren.*
- *Nicht die Stange der Gasdruckfeder beschädigen, sie darf nicht von stumpfen oder scheuernden Gegenständen bzw. von eventuellen ätzenden Chemikalien, Farbe, Öl oder Ähnlichem angegriffen werden.*
- *Die Stange der Gasdruckfeder nicht schmieren.*
- *Nicht montieren, wenn sie sichtbar beschädigt ist.*
- *Keine seitlichen Kräfte anwenden.*

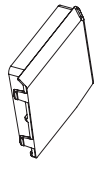
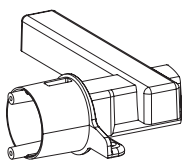
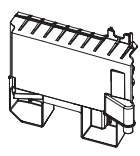
FR:

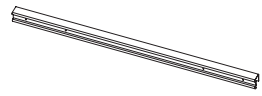
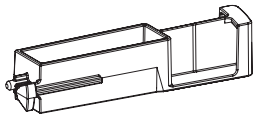
- *Ne pas essayer d'ouvrir, percer ou modifier de quelque manière que ce soit.*
- *Ne pas placer sur des sources de chaleur.*
- *Ne pas endommager la tige, elle ne doit pas être touchée par des objets contondants ou abrasifs ou par d'éventuelles substances chimiques corrosives, peinture, huile, etc.*
- *Ne pas lubrifier la tige.*
- *Ne pas installer si visiblement endommagés.*
- *Ne pas appliquer de forces latérales.*

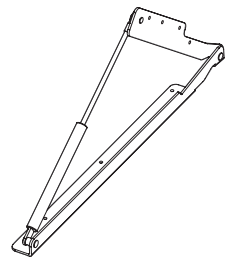
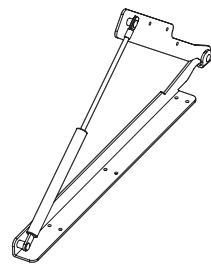
CONTENUTO / CONTENTS / CONTENU / CONTENIDOS / INHALT

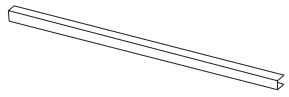
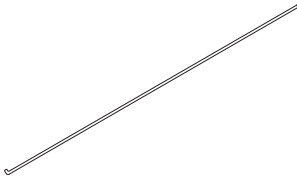
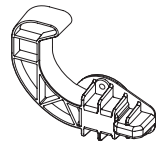
<p>Y</p>  <p>PZ / PCS 76</p>	<p>V</p>  <p>PZ / PCS 20</p>	<p>A3</p>  <p>PZ / PCS 5</p>	<p>D2</p>  <p>PZ / PCS 2</p>
<p>W</p>  <p>PZ / PCS 4</p>	<p>A2</p>  <p>PZ / PCS 1</p>	<p>A3</p>  <p>PZ / PCS 3</p>	<p>A1</p>  <p>PZ / PCS 1</p>
<p>F</p>  <p>PZ / PCS 1</p>	<p>G</p>  <p>PZ / PCS 1</p>	<p>L</p>  <p>PZ / PCS 1</p>	
<p>B</p>  <p>PZ / PCS 2</p>	<p>K1</p>  <p>PZ / PCS 2</p>	<p>I</p>  <p>PZ / PCS 1</p>	
<p>C</p>  <p>PZ / PCS 2</p>	<p>T</p>  <p>PZ / PCS 3</p>	<p>X</p>  <p>PZ / PCS 1</p>	

<p>S</p>  <p>PZ / PCS 2</p>	<p>K3</p>  <p>PZ / PCS 1</p>	<p>Z2</p>  <p>PZ / PCS 4</p>	<p>K2</p>  <p>PZ / PCS 8</p>
<p>K4</p>  <p>PZ / PCS 2</p>	<p>H</p>  <p>PZ / PCS 1</p>	<p>Z1</p>  <p>PZ / PCS 2</p>	<p>Z3</p>  <p>PZ / PCS 2</p>
<p>P</p>  <p>PZ / PCS 1</p>	<p>E</p>  <p>PZ / PCS 1</p>	<p>X3</p>  <p>PZ / PCS 1</p>	<p>X2</p>  <p>PZ / PCS 2</p>
<p>N</p>  <p>PZ / PCS 1</p>	<p>D</p>  <p>PZ / PCS 2</p>	<p>K5</p>  <p>PZ / PCS 1</p>	<p>K6</p>  <p>PZ / PCS 1</p>
<p>D4</p>  <p>PZ / PCS 2</p>	<p>K7</p>  <p>PZ / PCS 2</p>	<p>C2</p>  <p>PZ / PCS 1</p>	<p>Q</p>  <p>PZ / PCS 1</p>  <p>PZ / PCS 1</p>

1

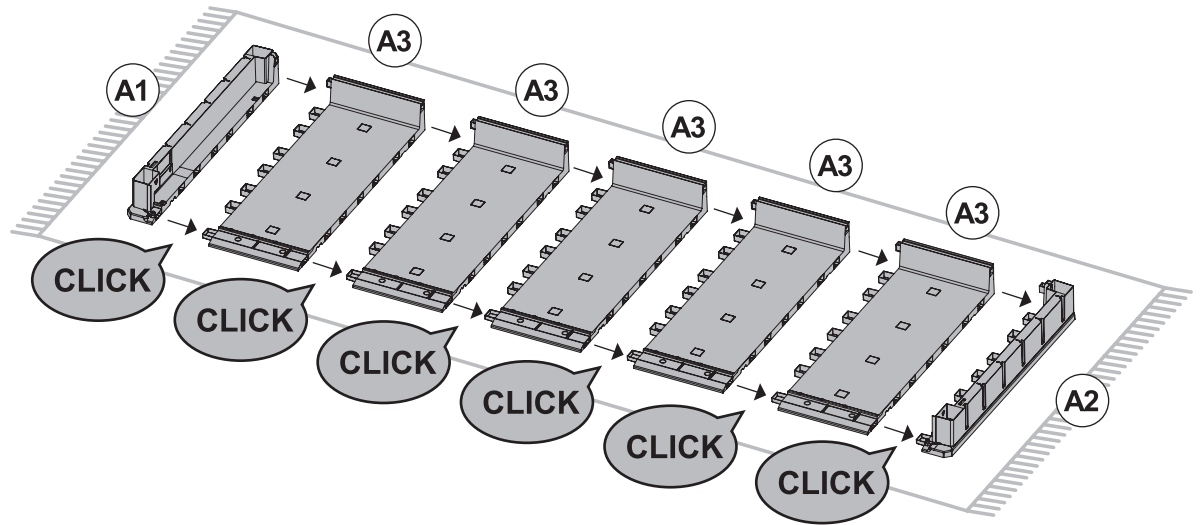
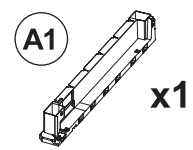
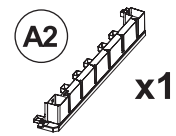
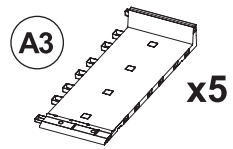

2

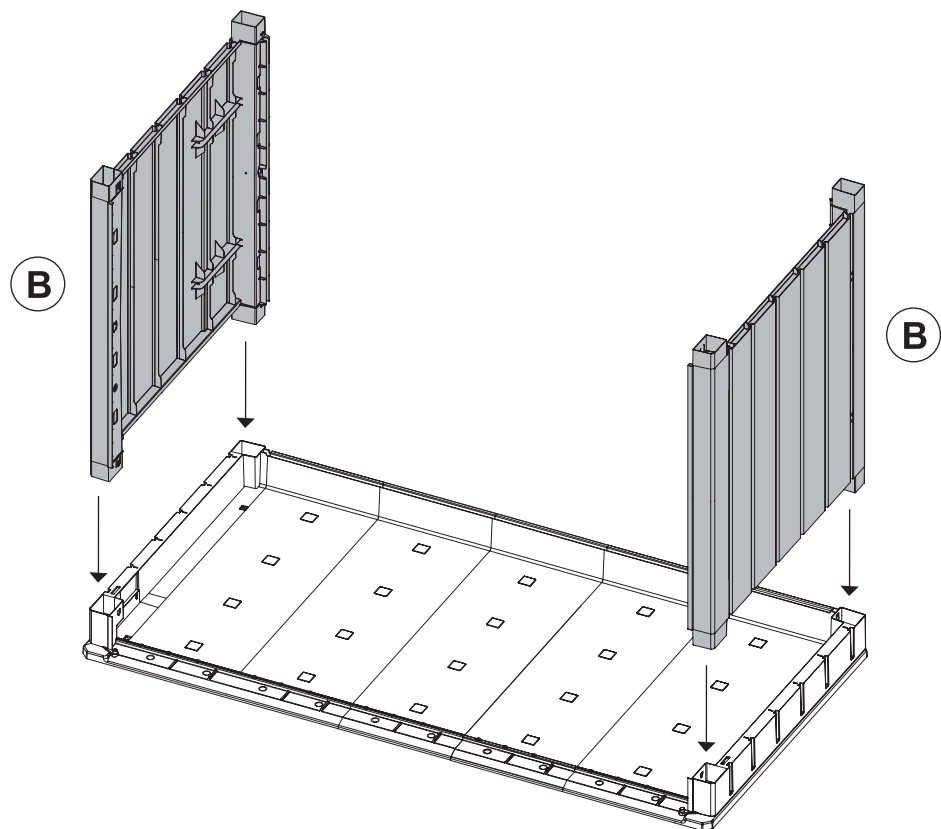
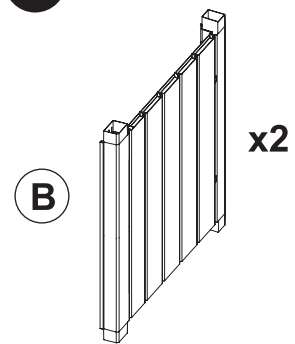

3

W

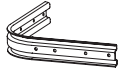

x2

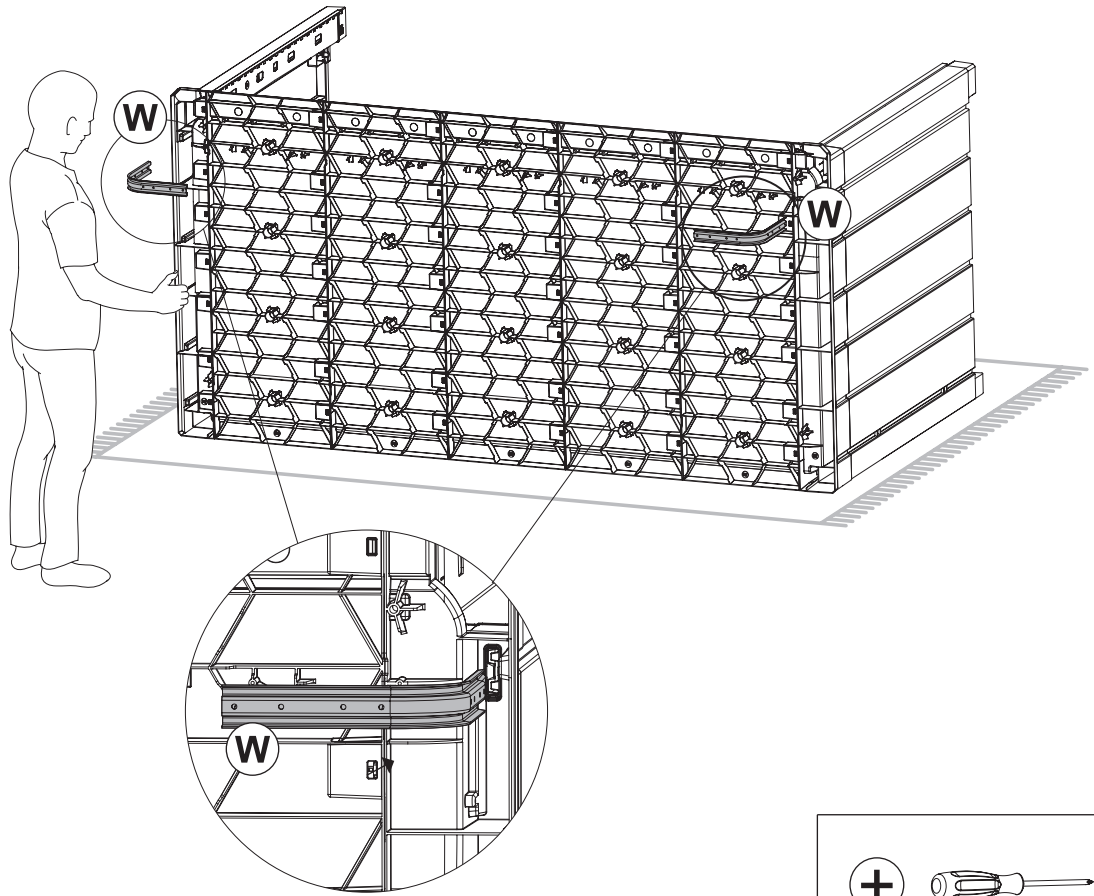

+

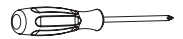

4

Y



x4

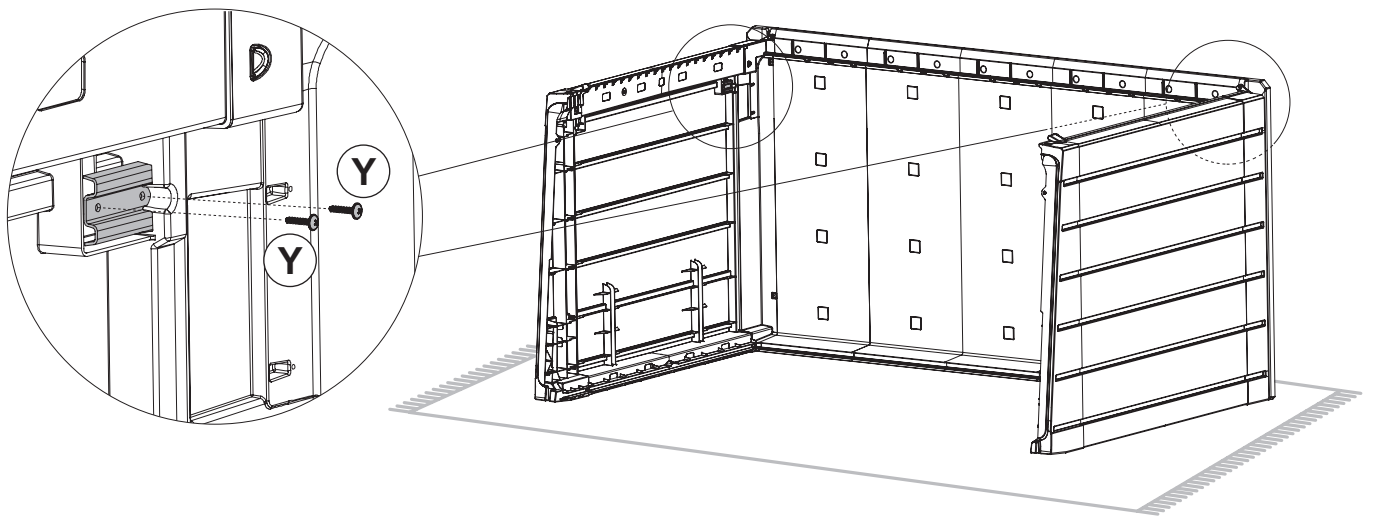

5

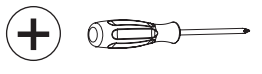

Y x4

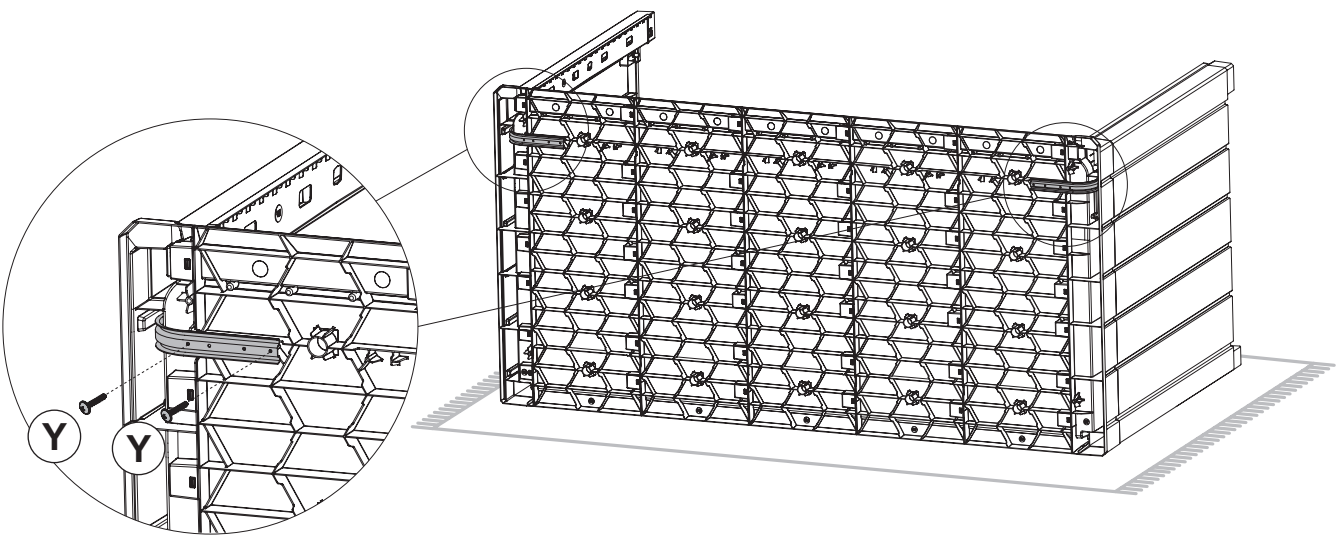

6

I x1

C x1

T x3

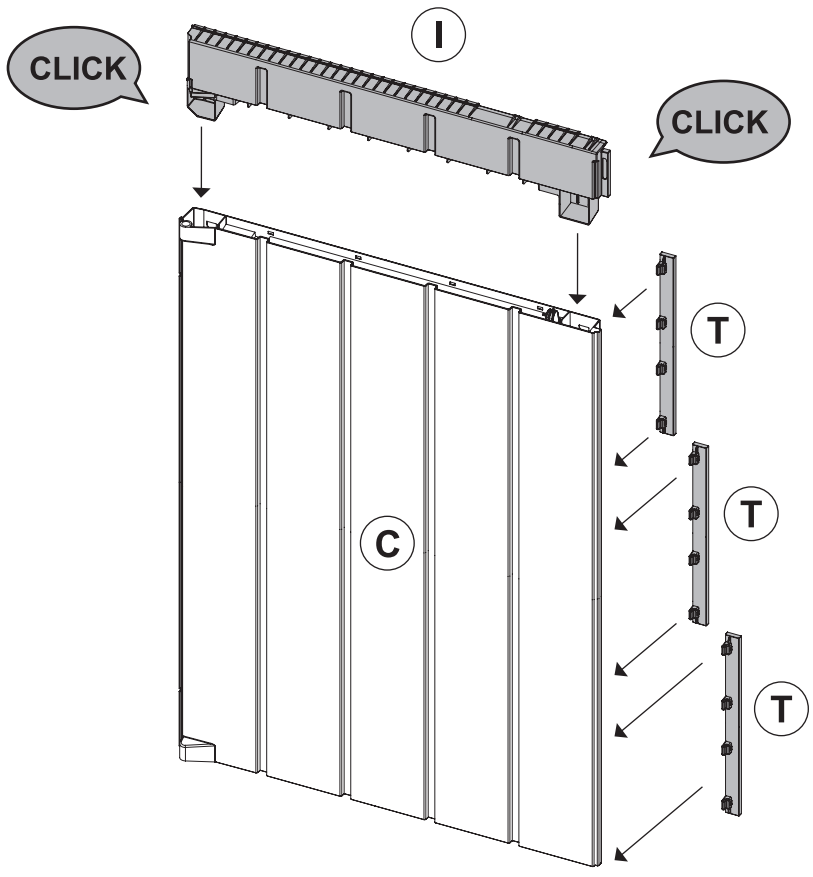

7

P x1

N x1

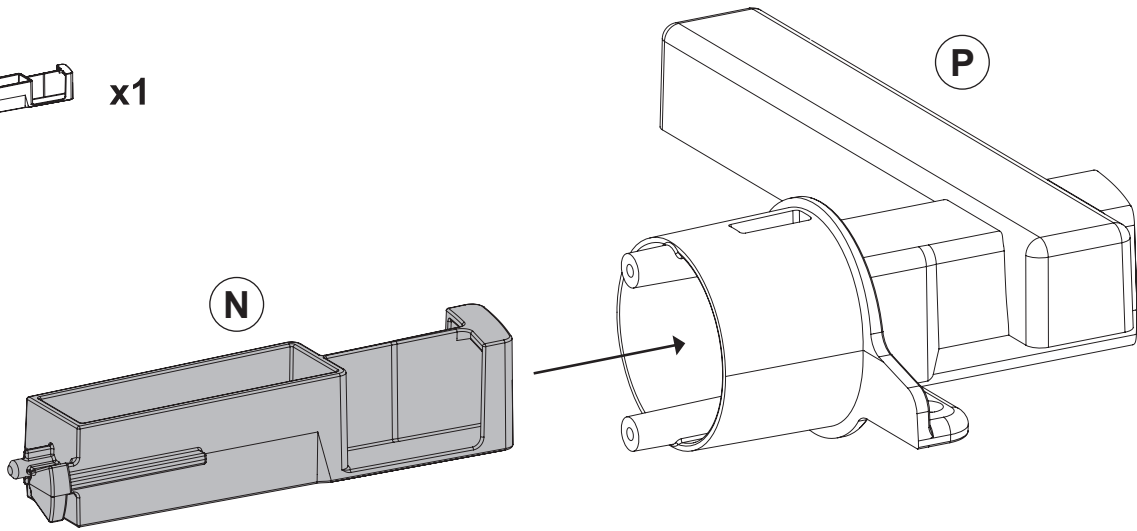

8

L x1

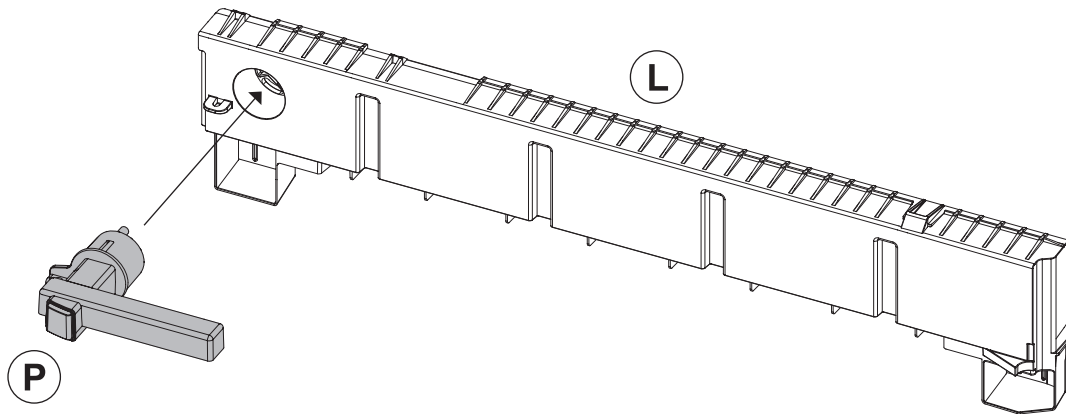

9

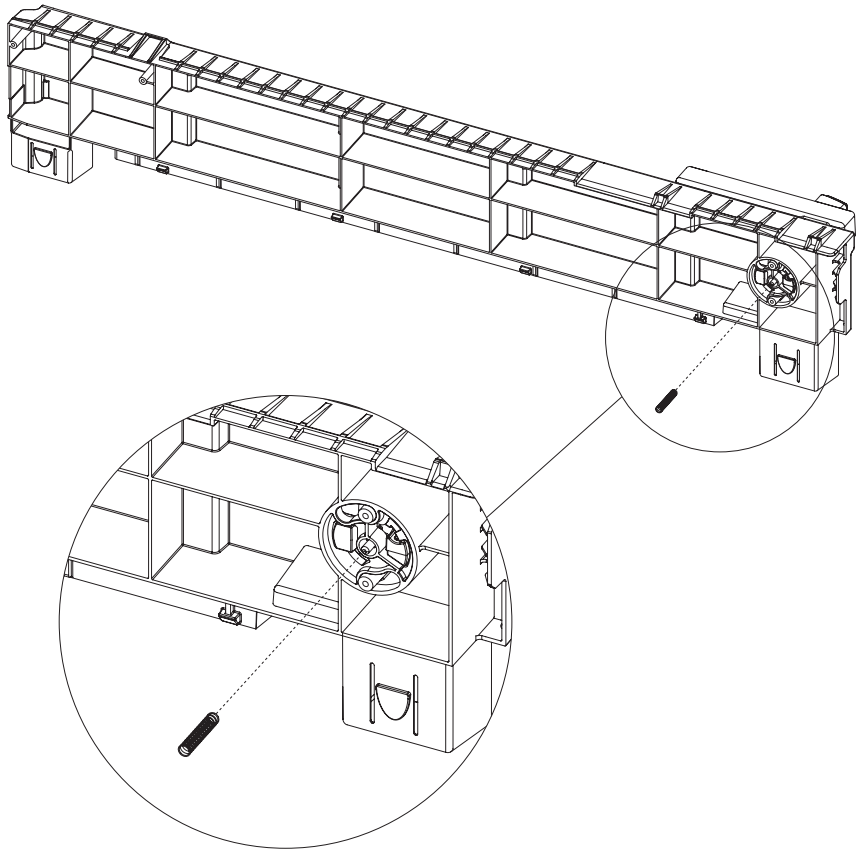
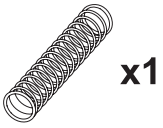

10

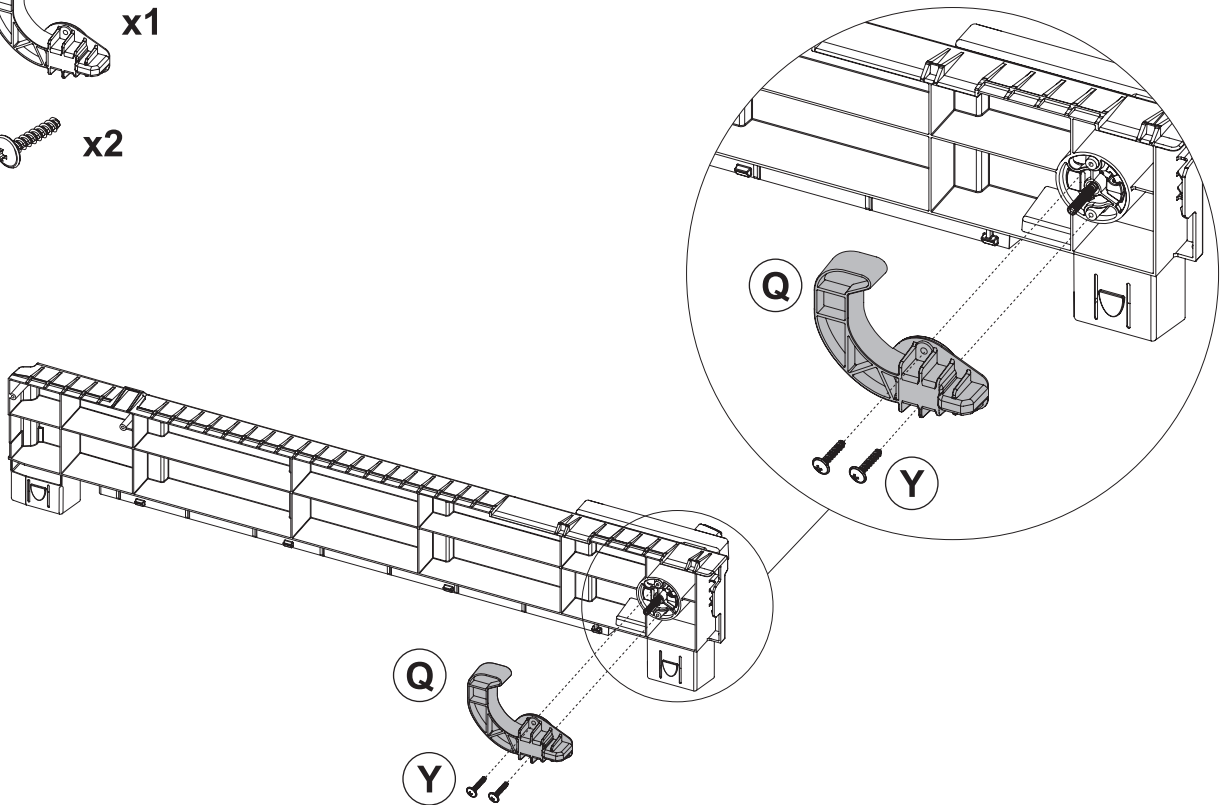
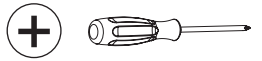
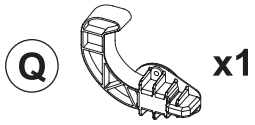

11

C

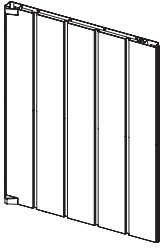

x1

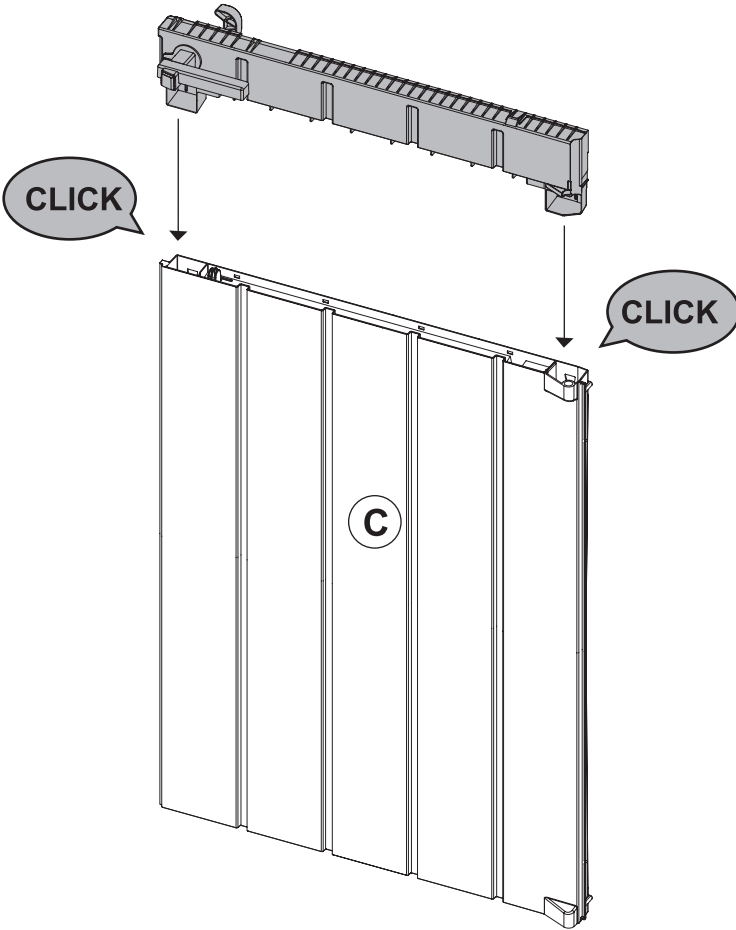

12

C2

x1

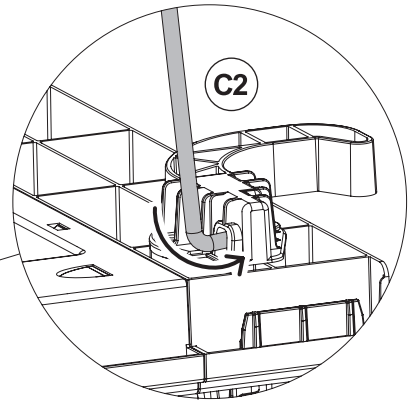
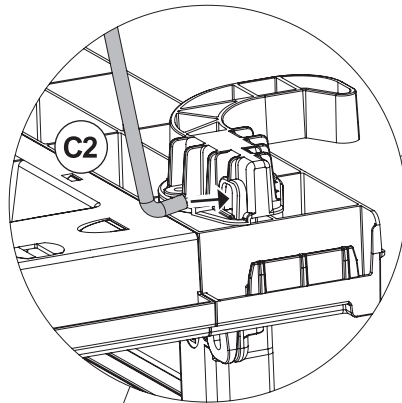
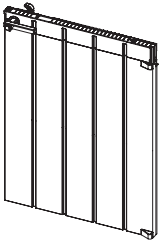

C2

12.1

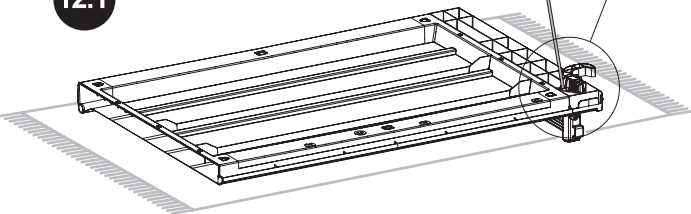

12.2

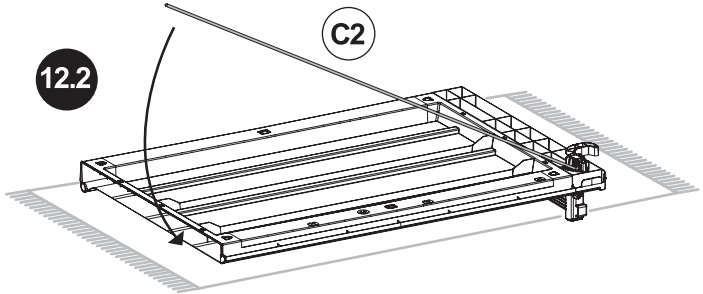

13

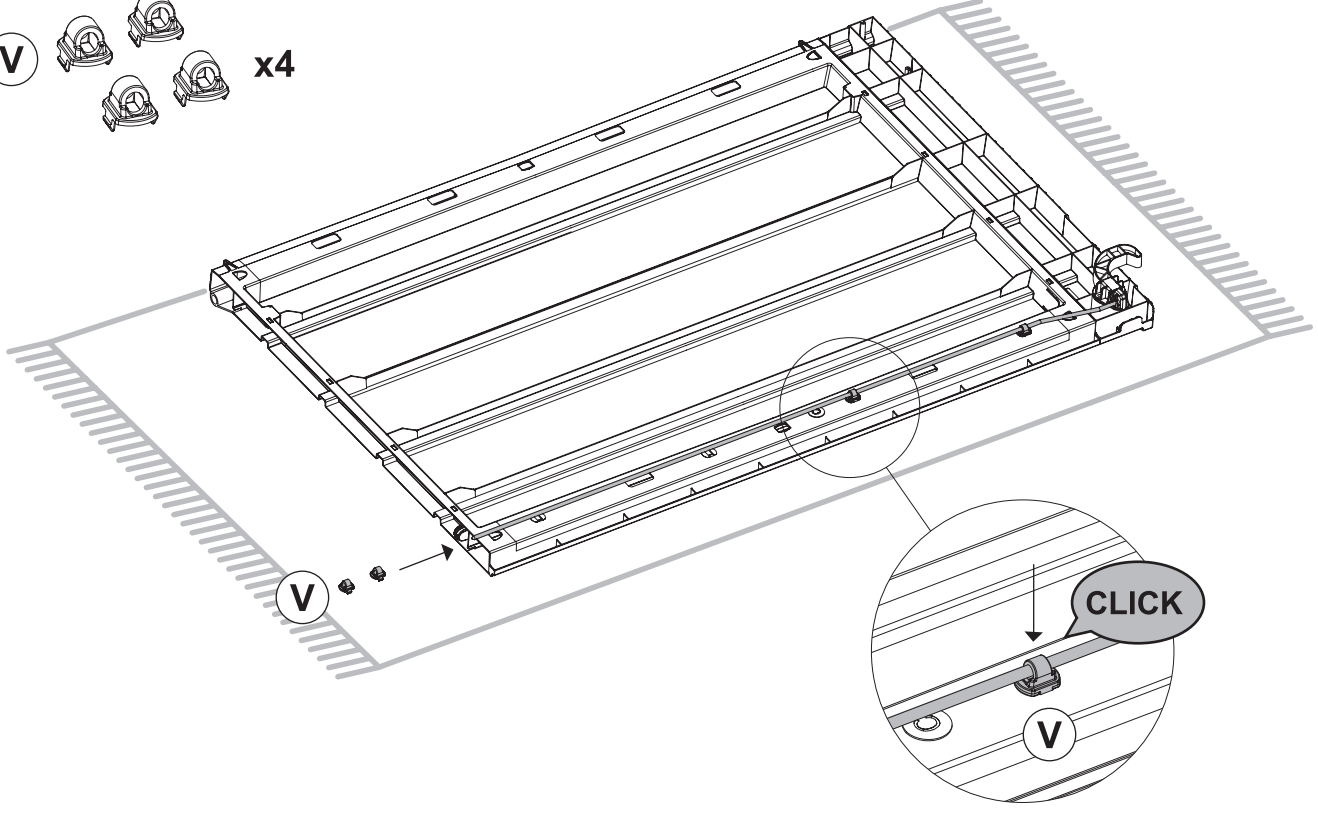
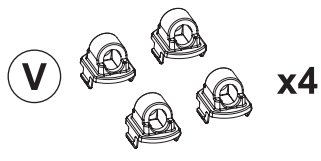

14

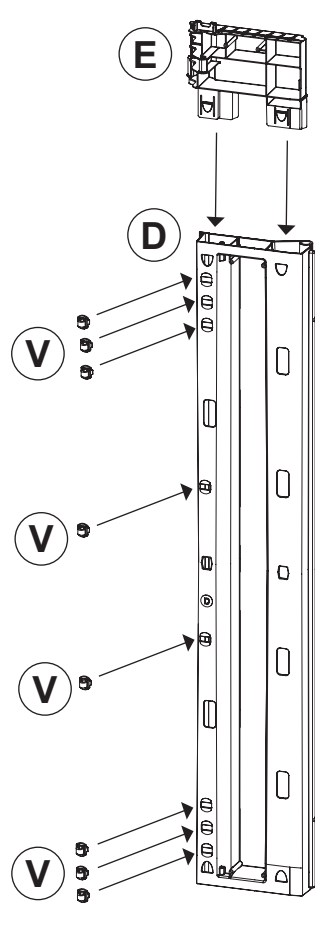
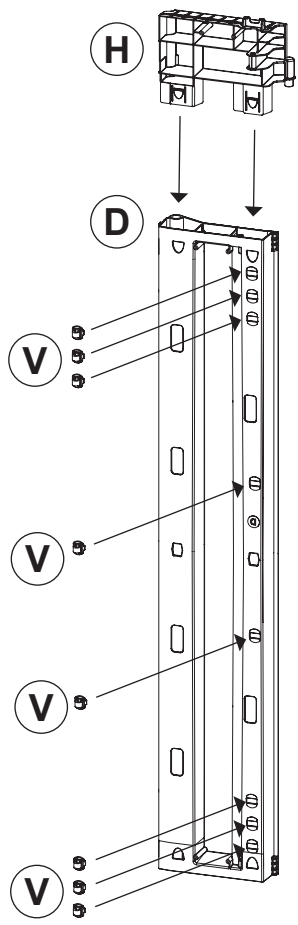
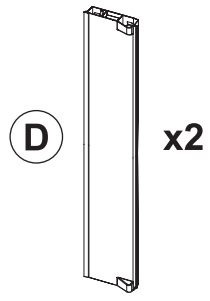
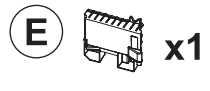
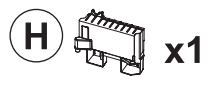

15

D2 x2

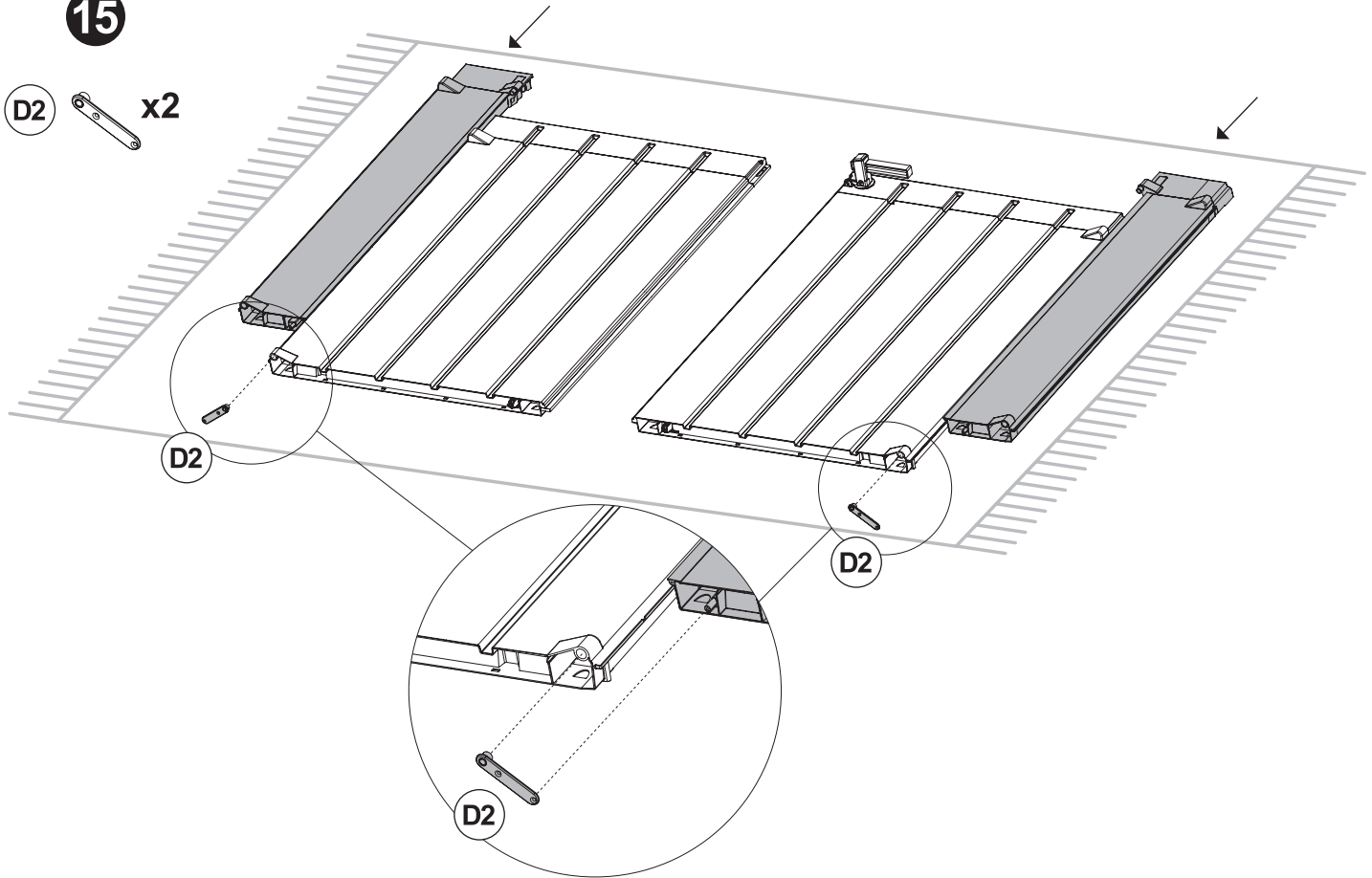

16

Y x4

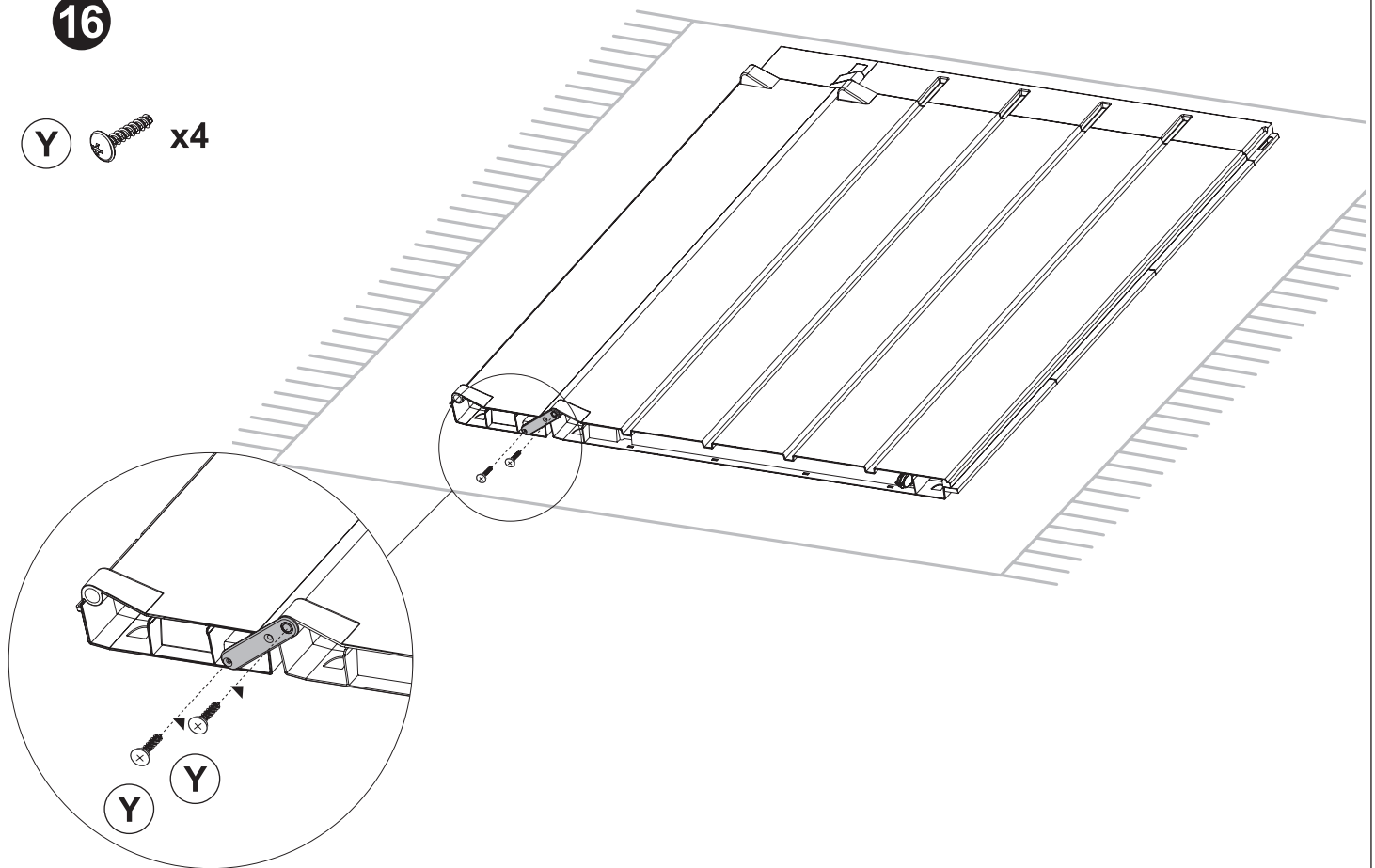

17

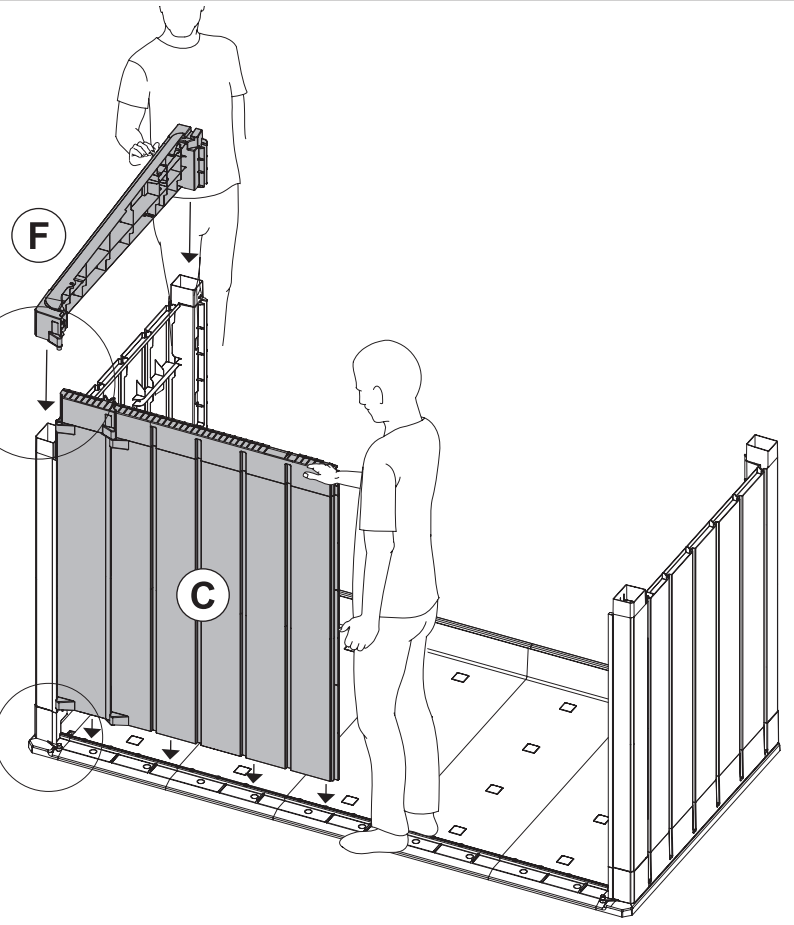
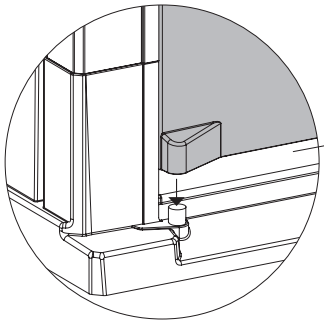
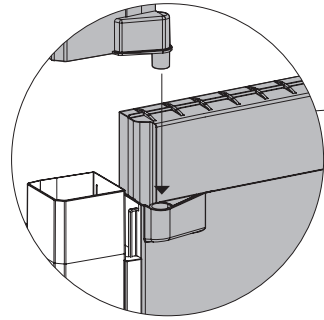
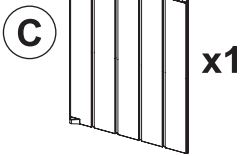
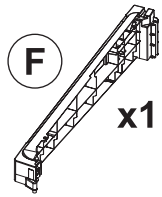

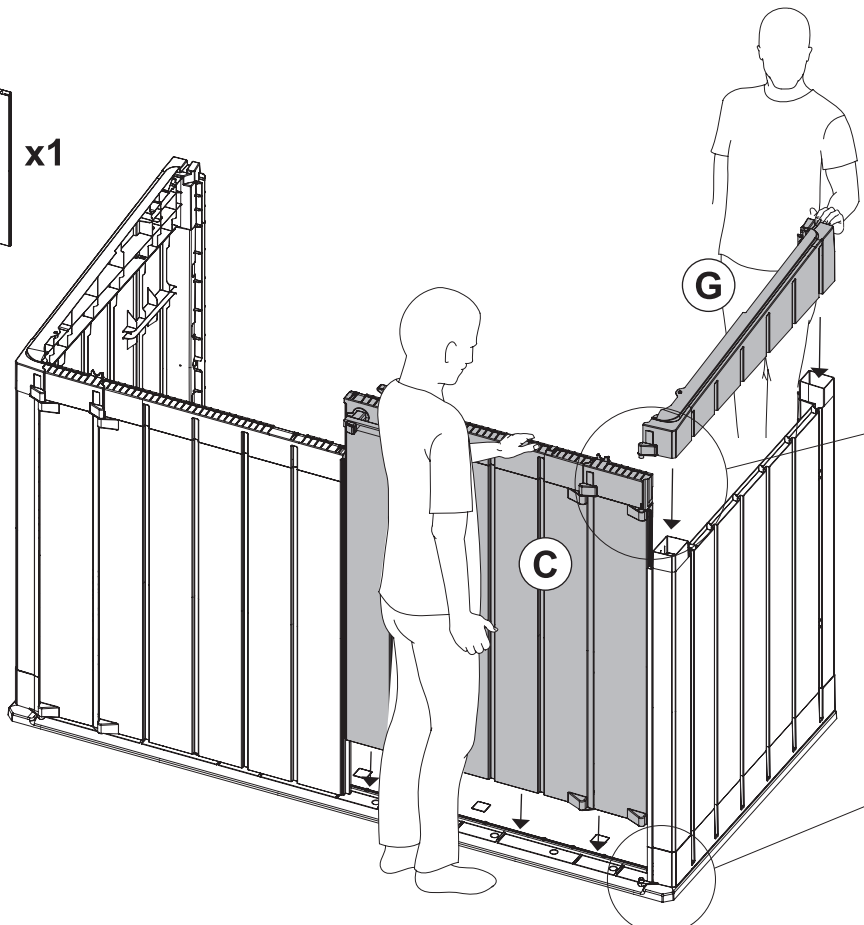
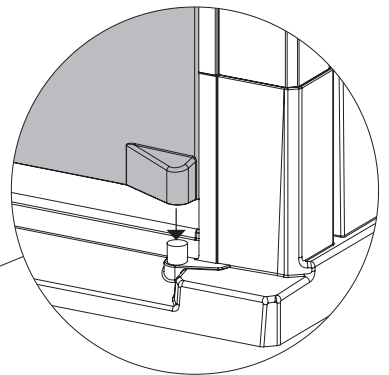
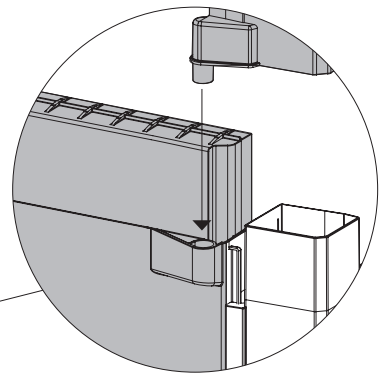
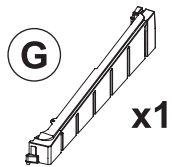
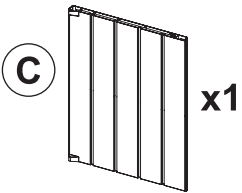

18

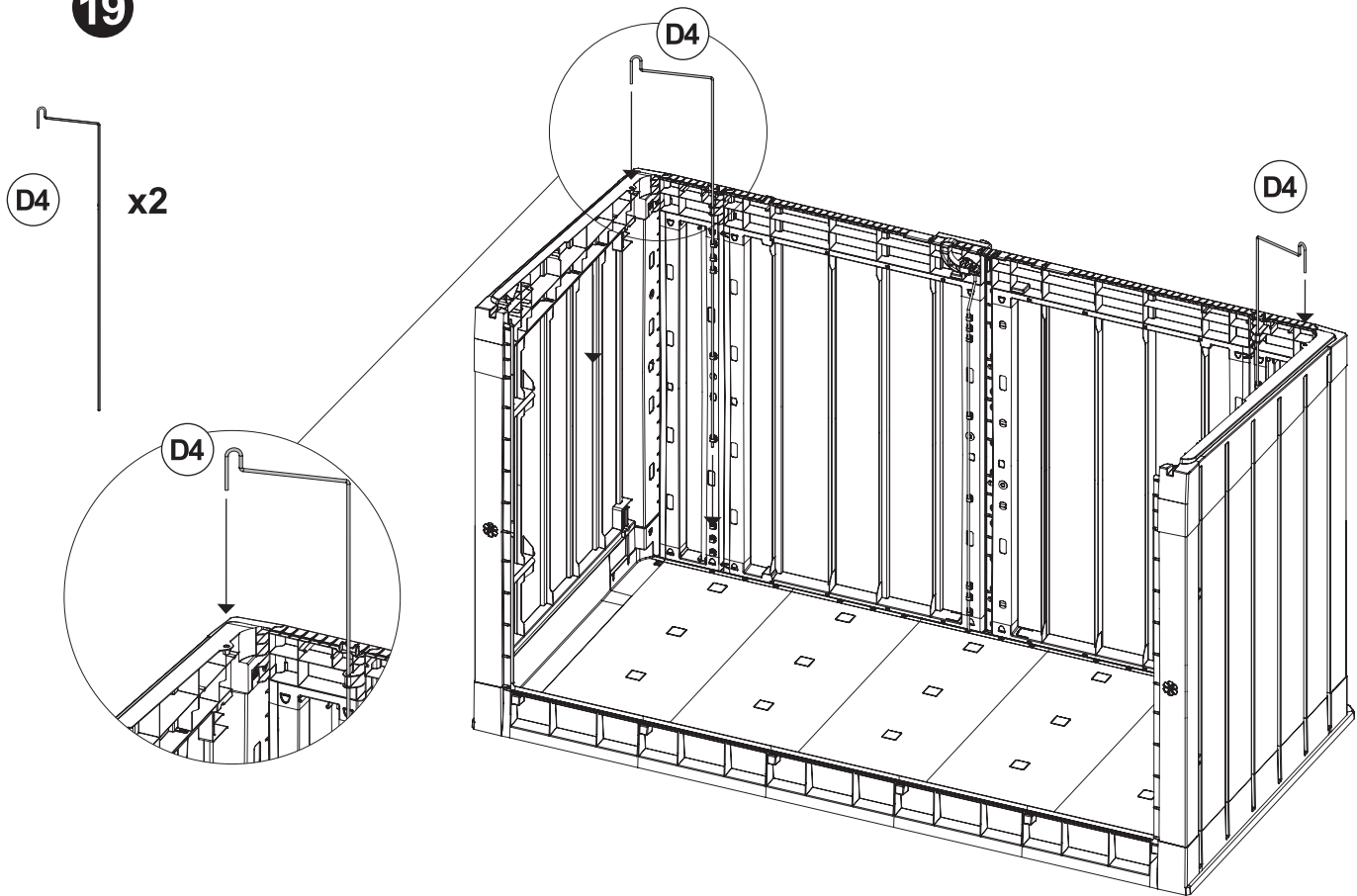

19

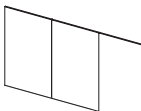

20

- (X)  x1
- (X2)  x2
- (X3)  x1

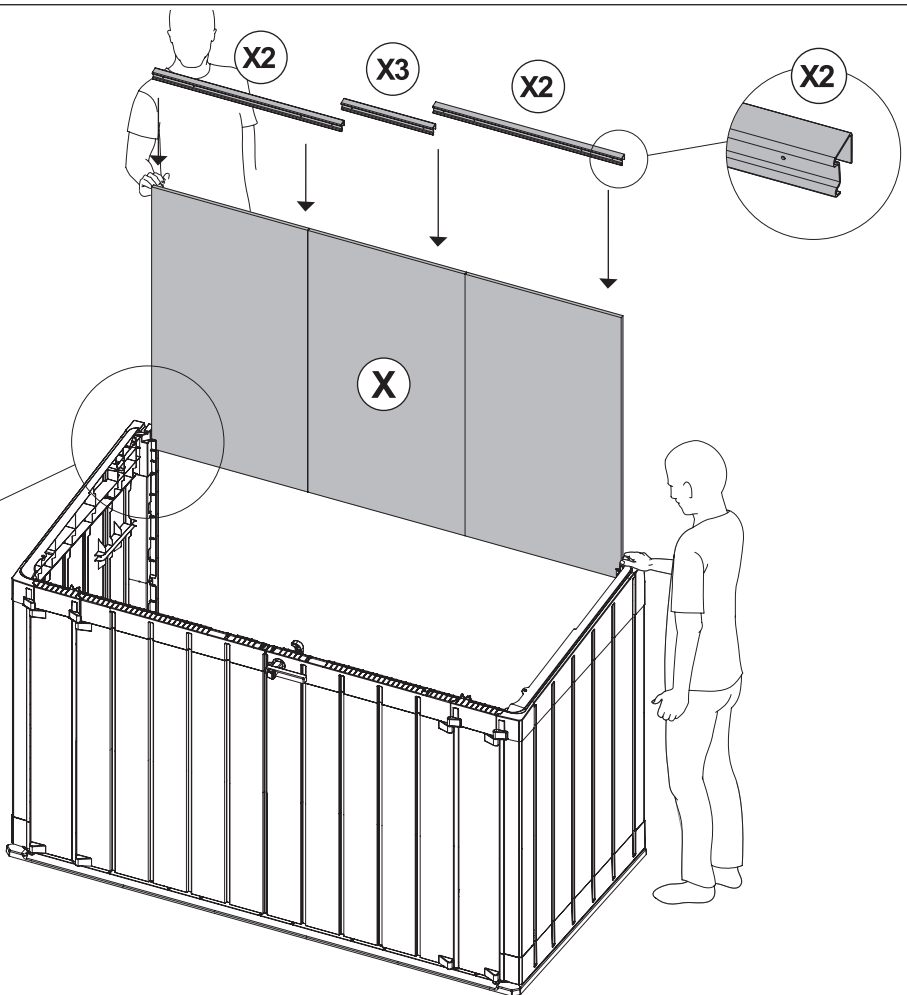
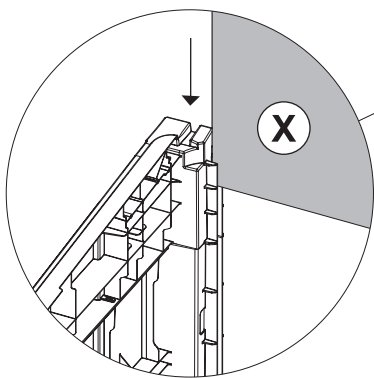

21

Y  x6

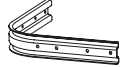
W  x2

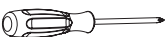
+ 

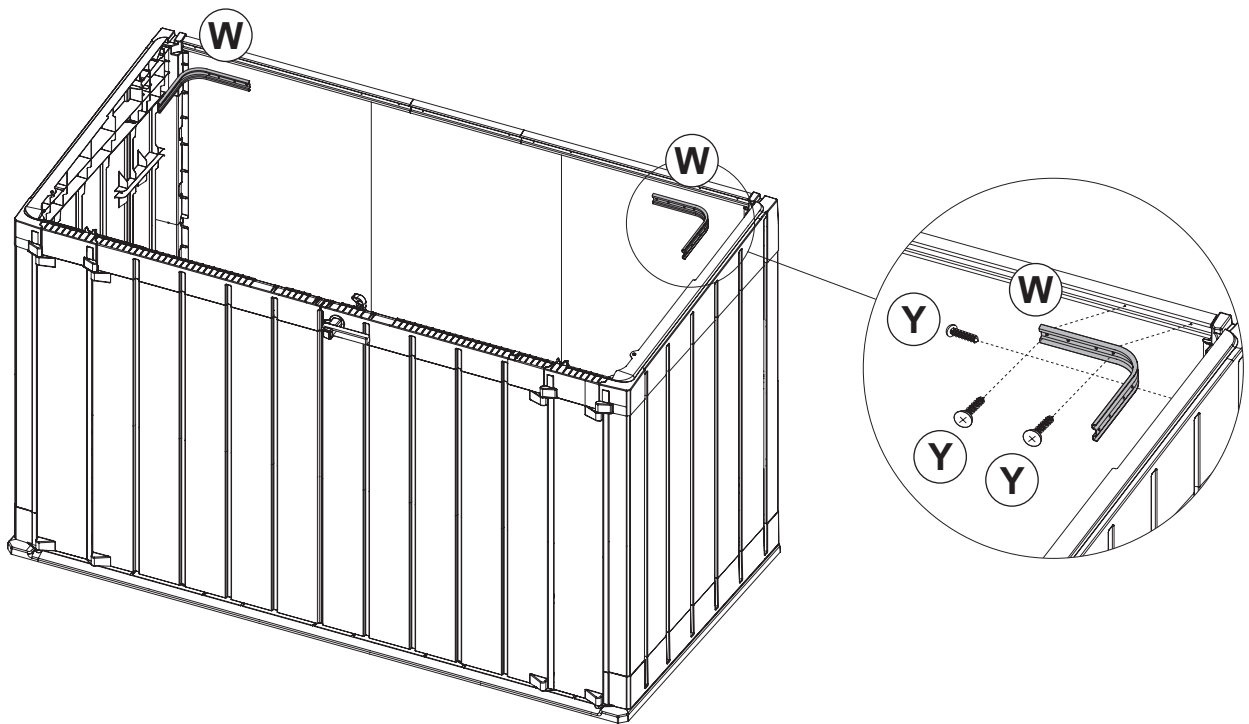

22

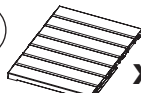
K1  x2

K7  x2

K2  x8

K3  x1

Z1  x2

Z2  x4

Z3  x2

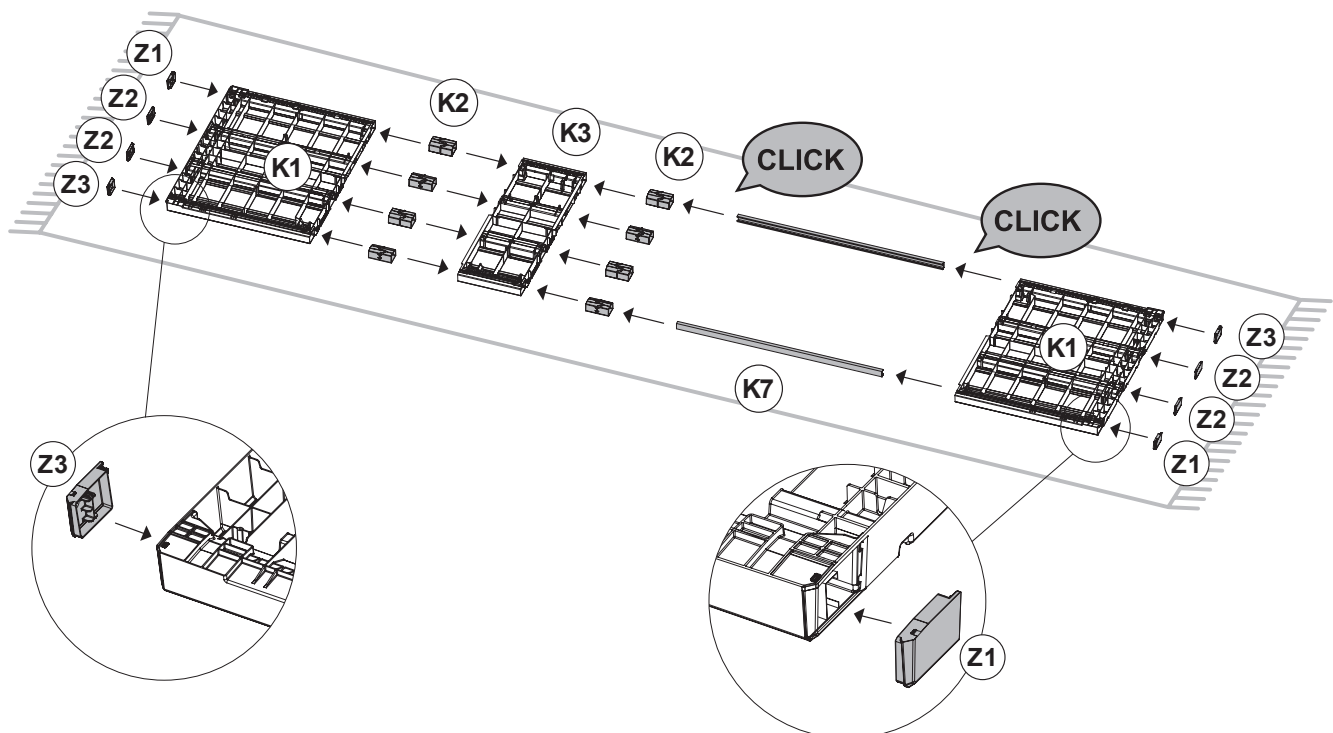

23

K4

x2

Y

x4

+

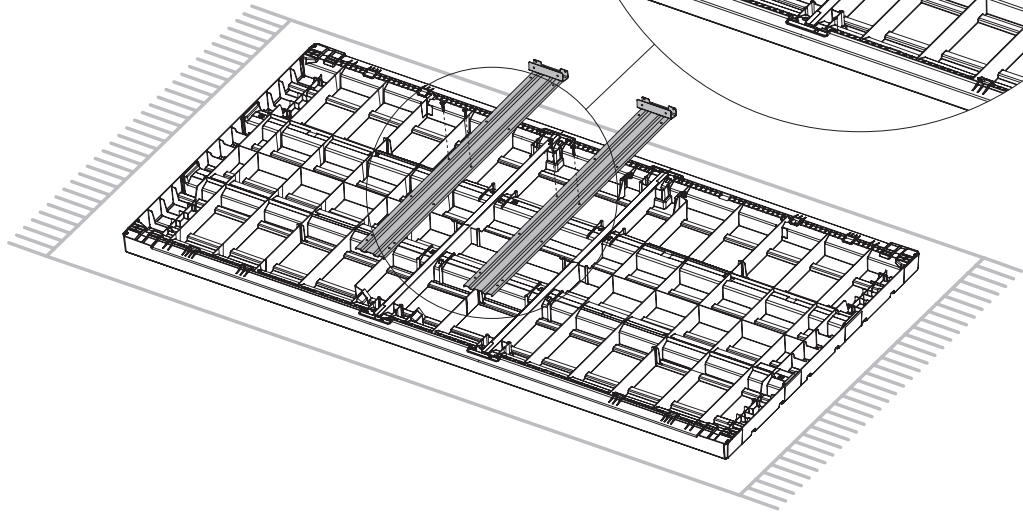
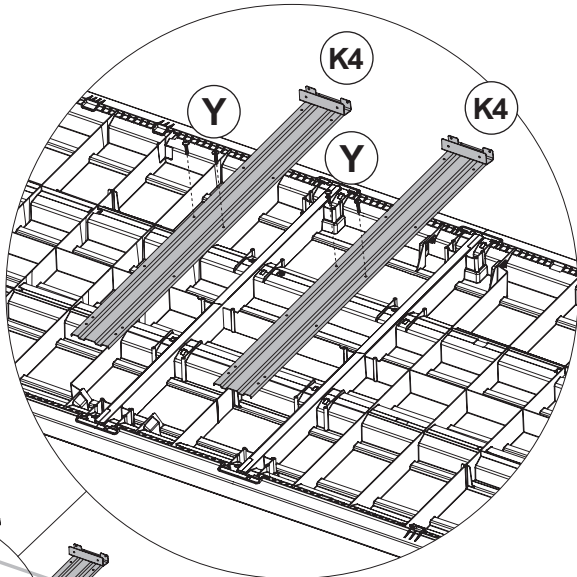
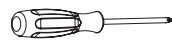

24

Y

x20

S

x2

+

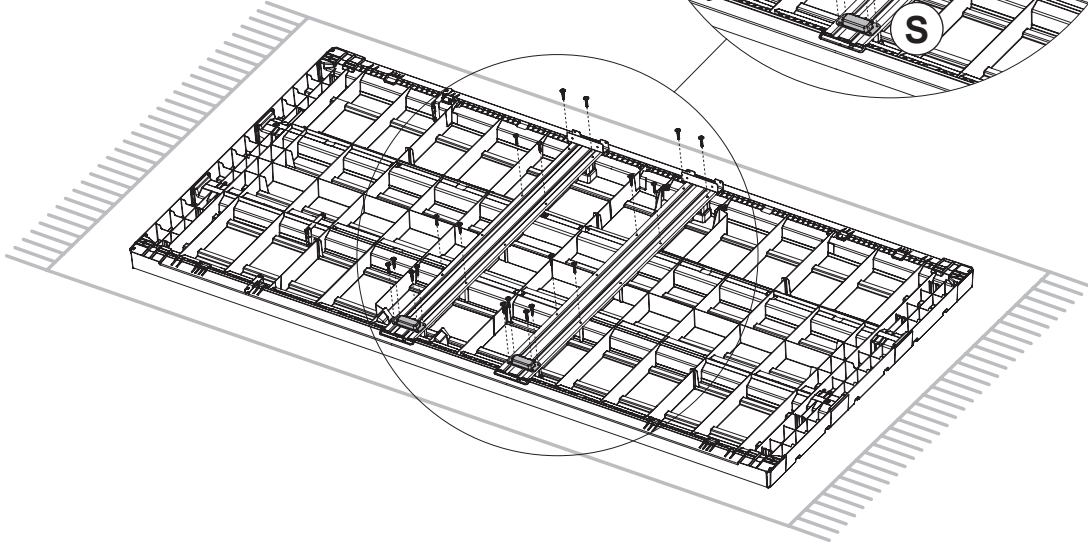
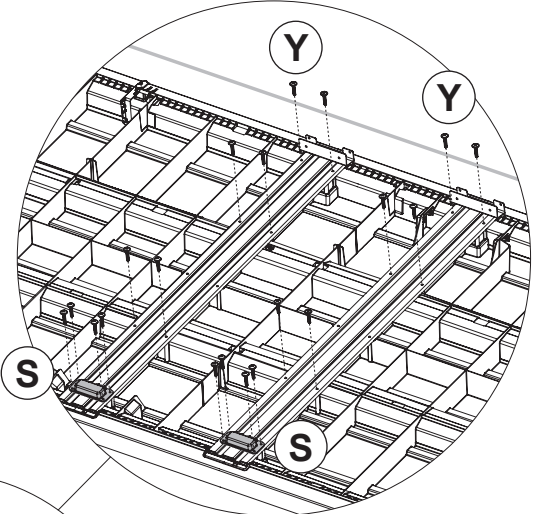
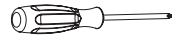

25

Y x12

K5 x1

K6 x1

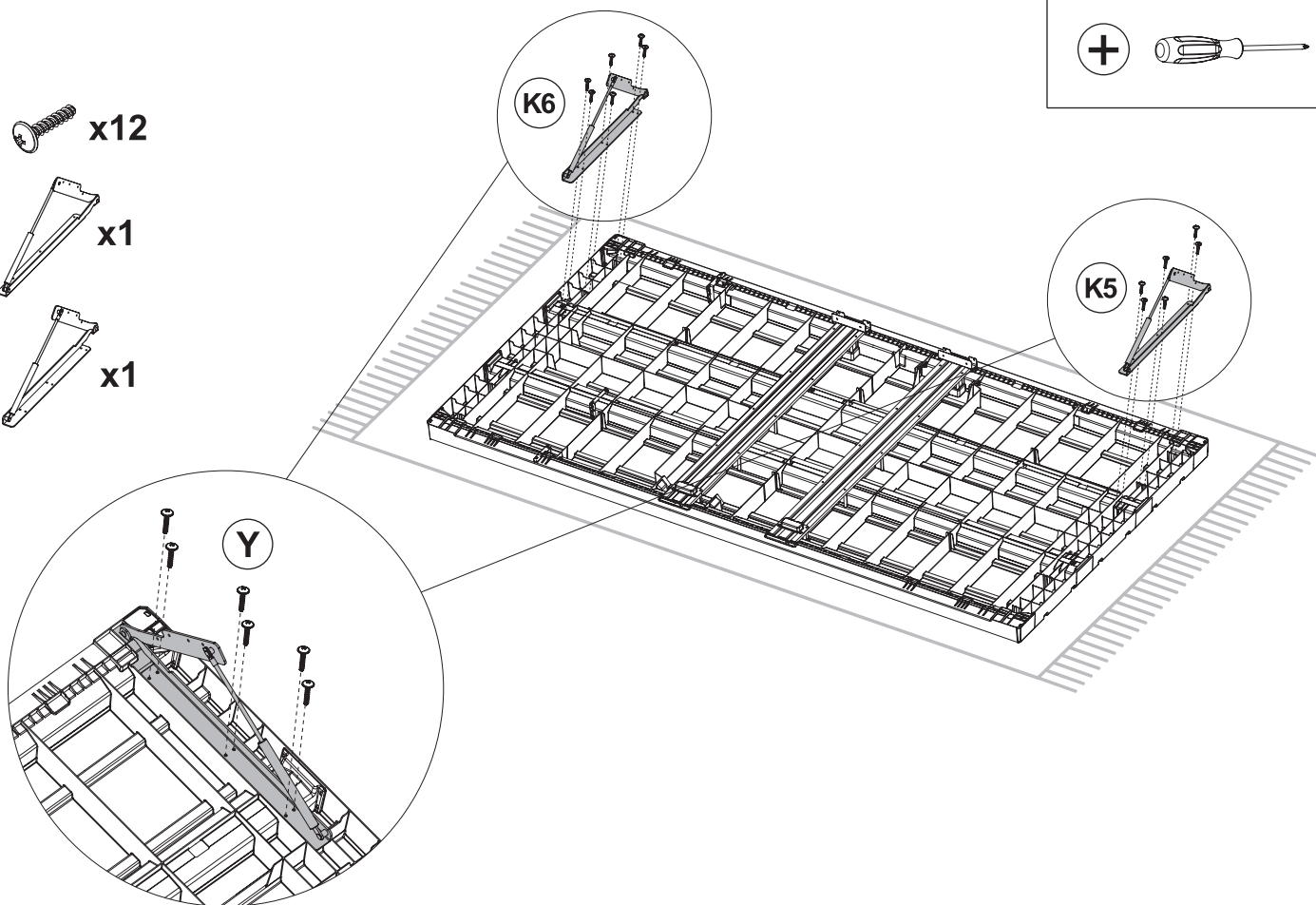
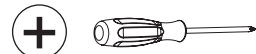

26

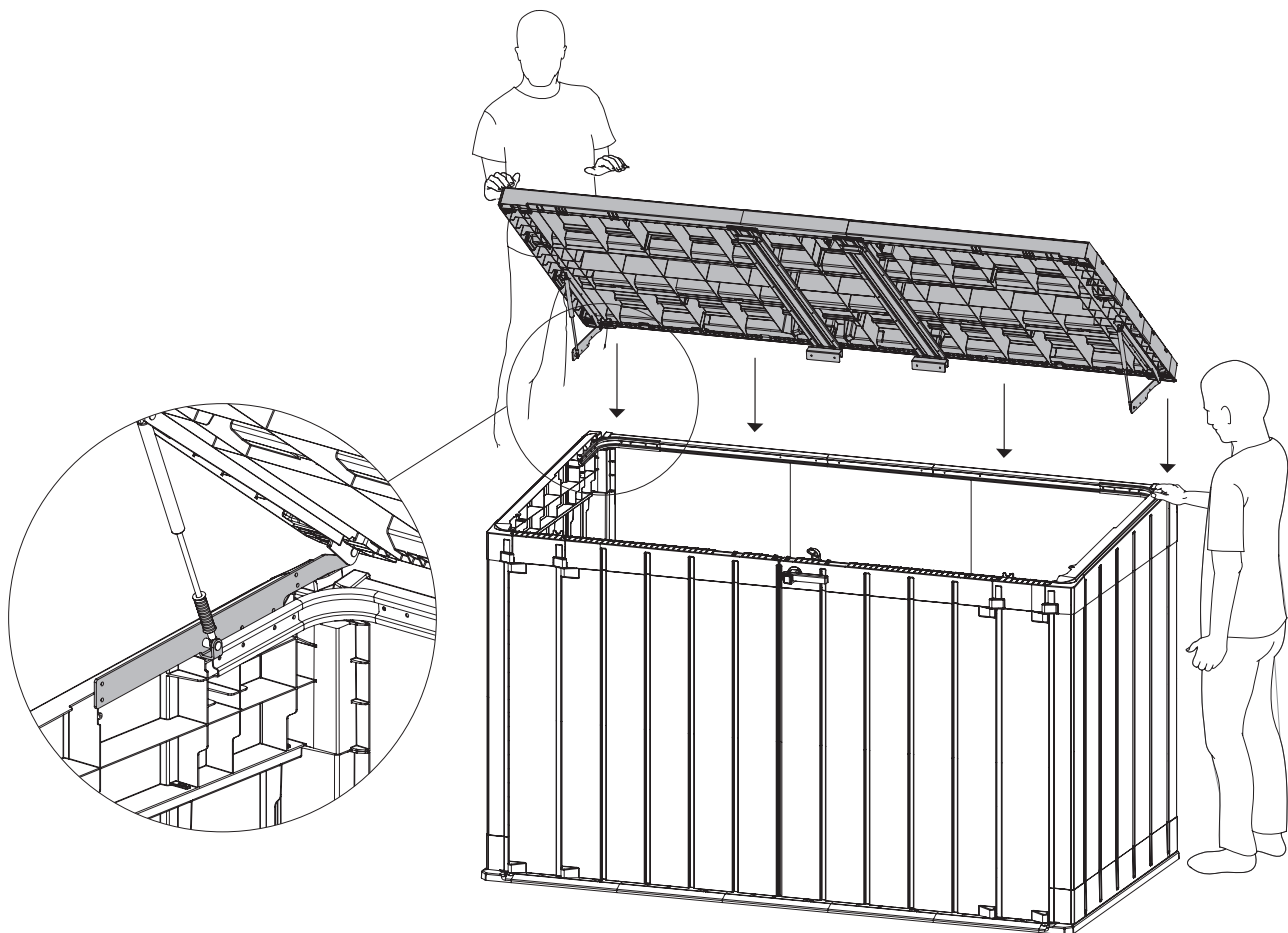

27

Y  x16

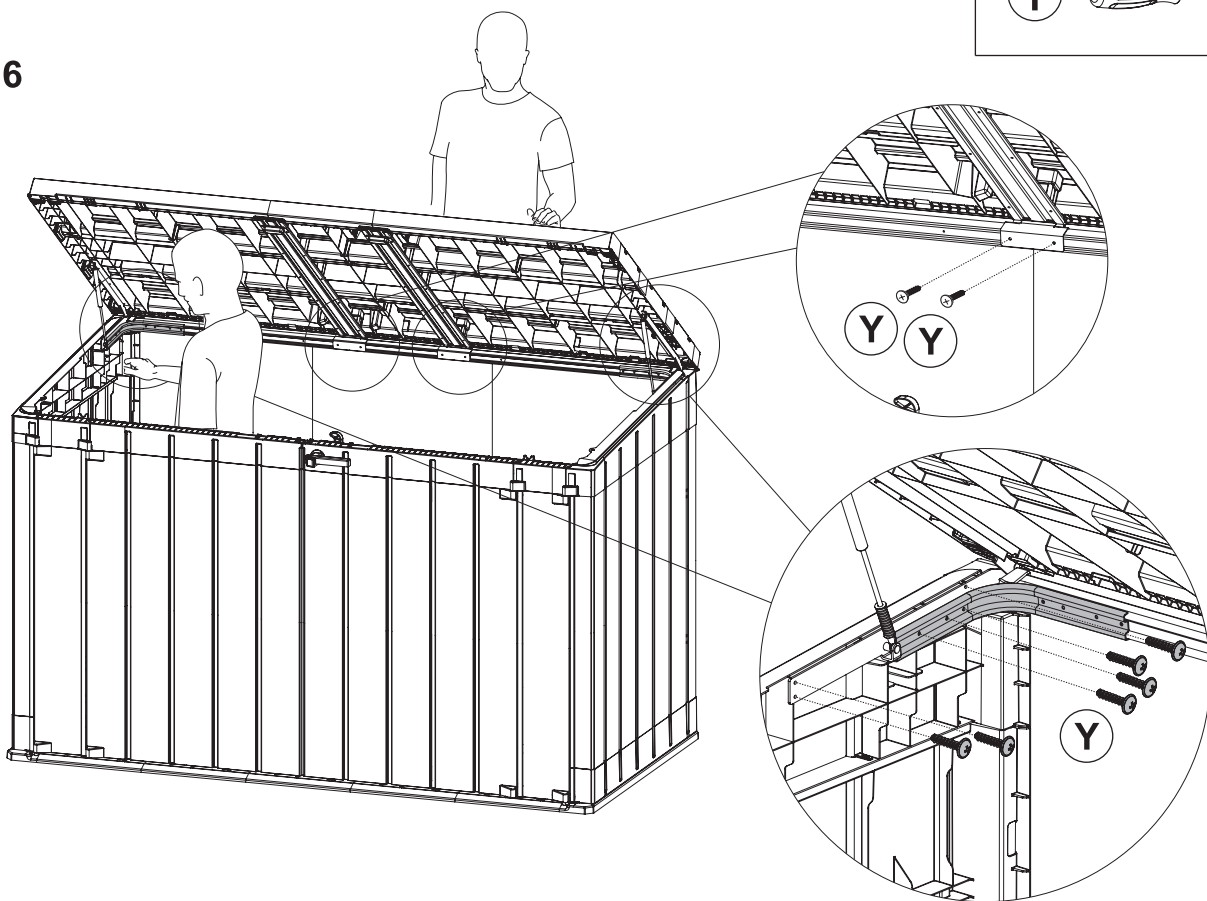
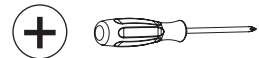

28

Y  x4

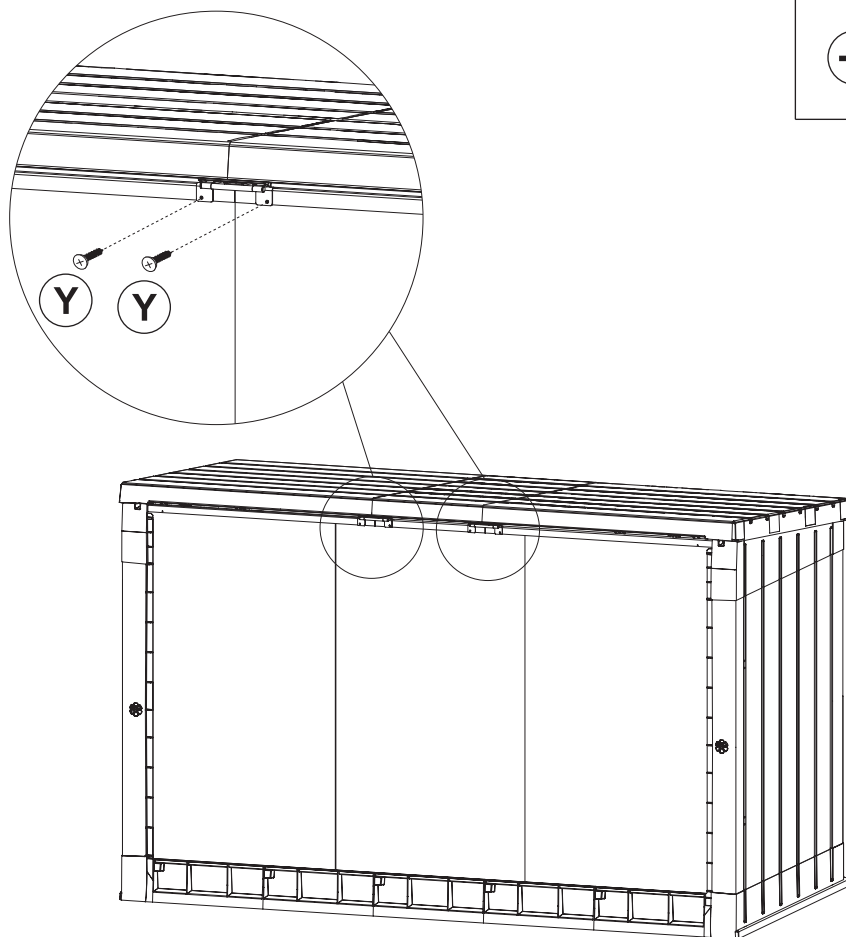
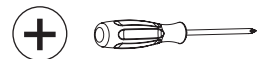

29

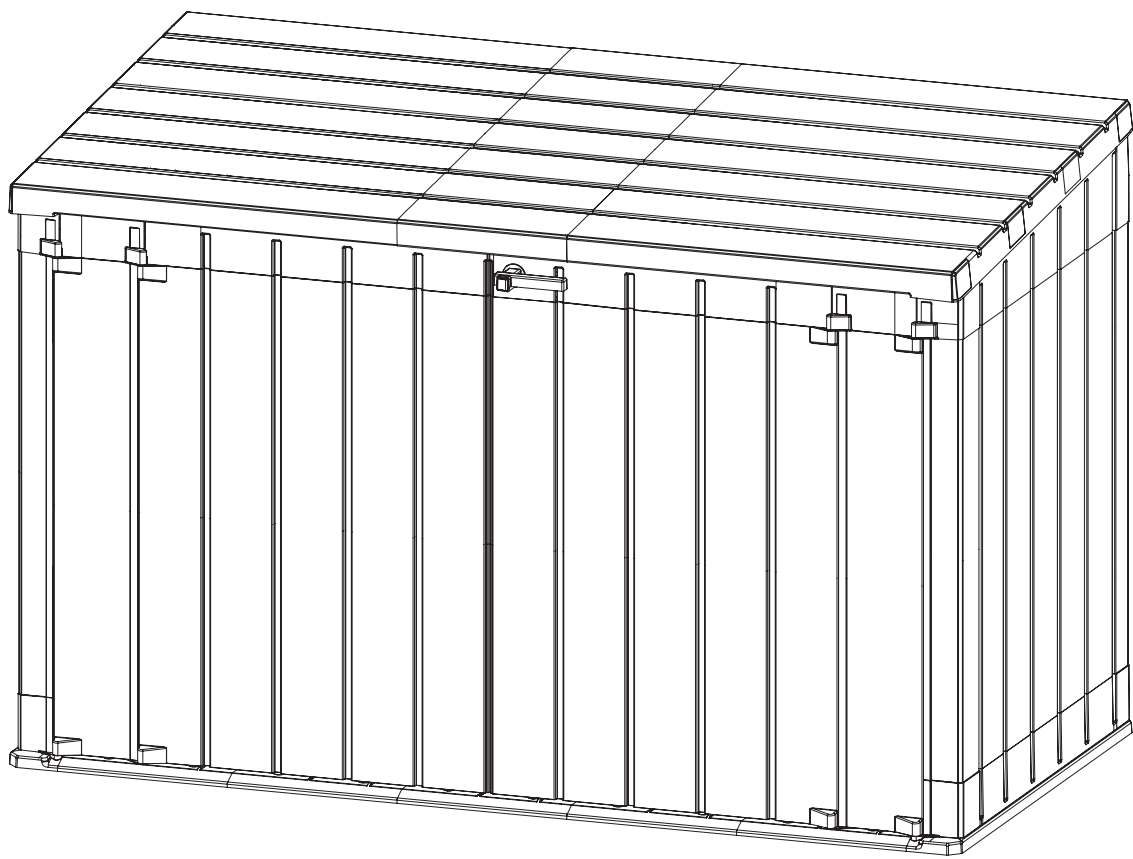

OPZIONE 1 / OPTION 1

IT: Catenella per apertura coperchio pattumiere (pattumiere non incluse)

EN: Chain for bin lid opening (bins not included)

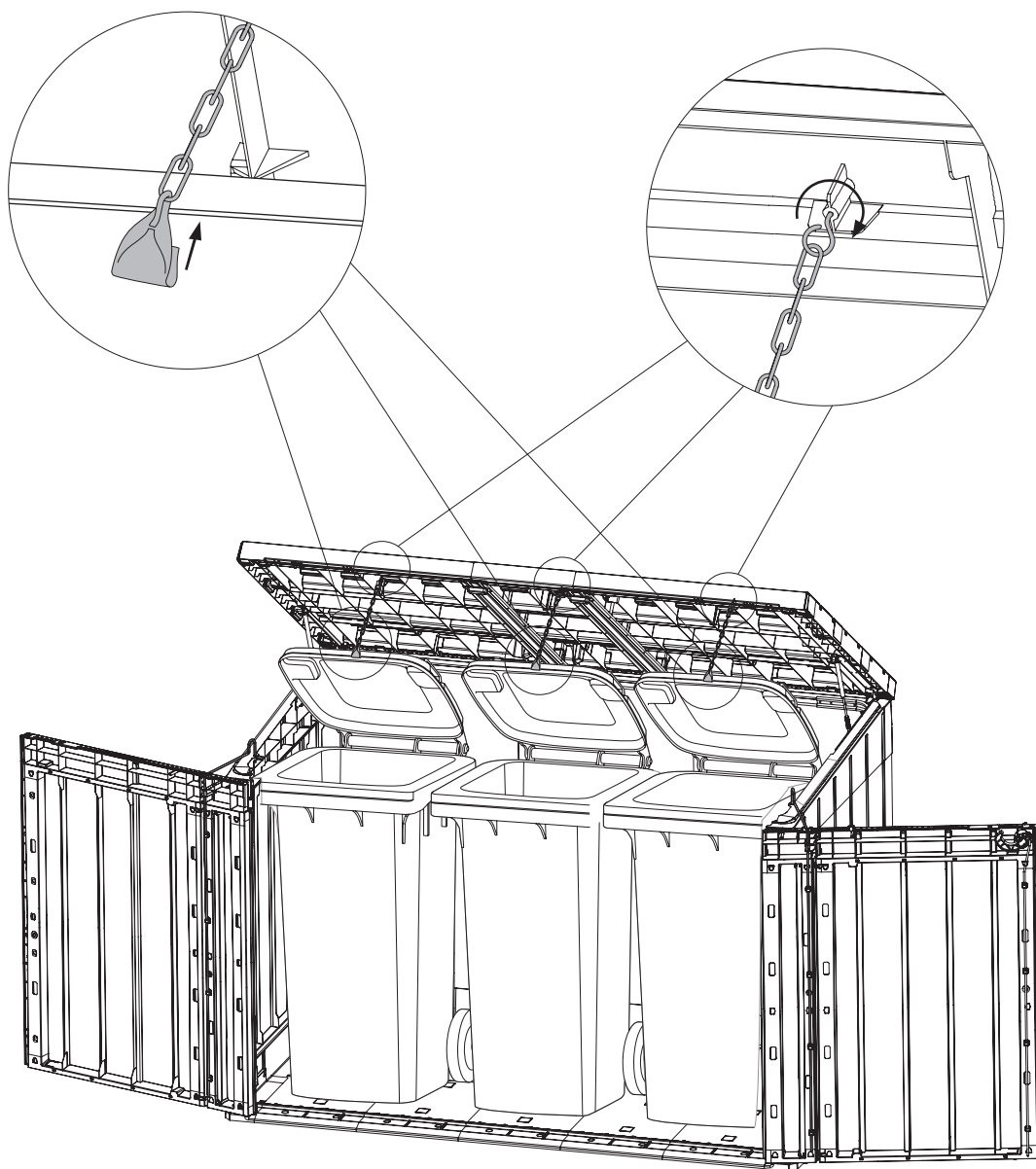
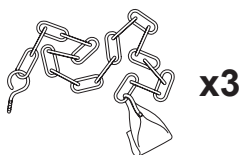

OPZIONE 2 / OPTION 2

IT: Fissaggio a muro **EN:** Wall mounting

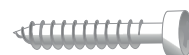
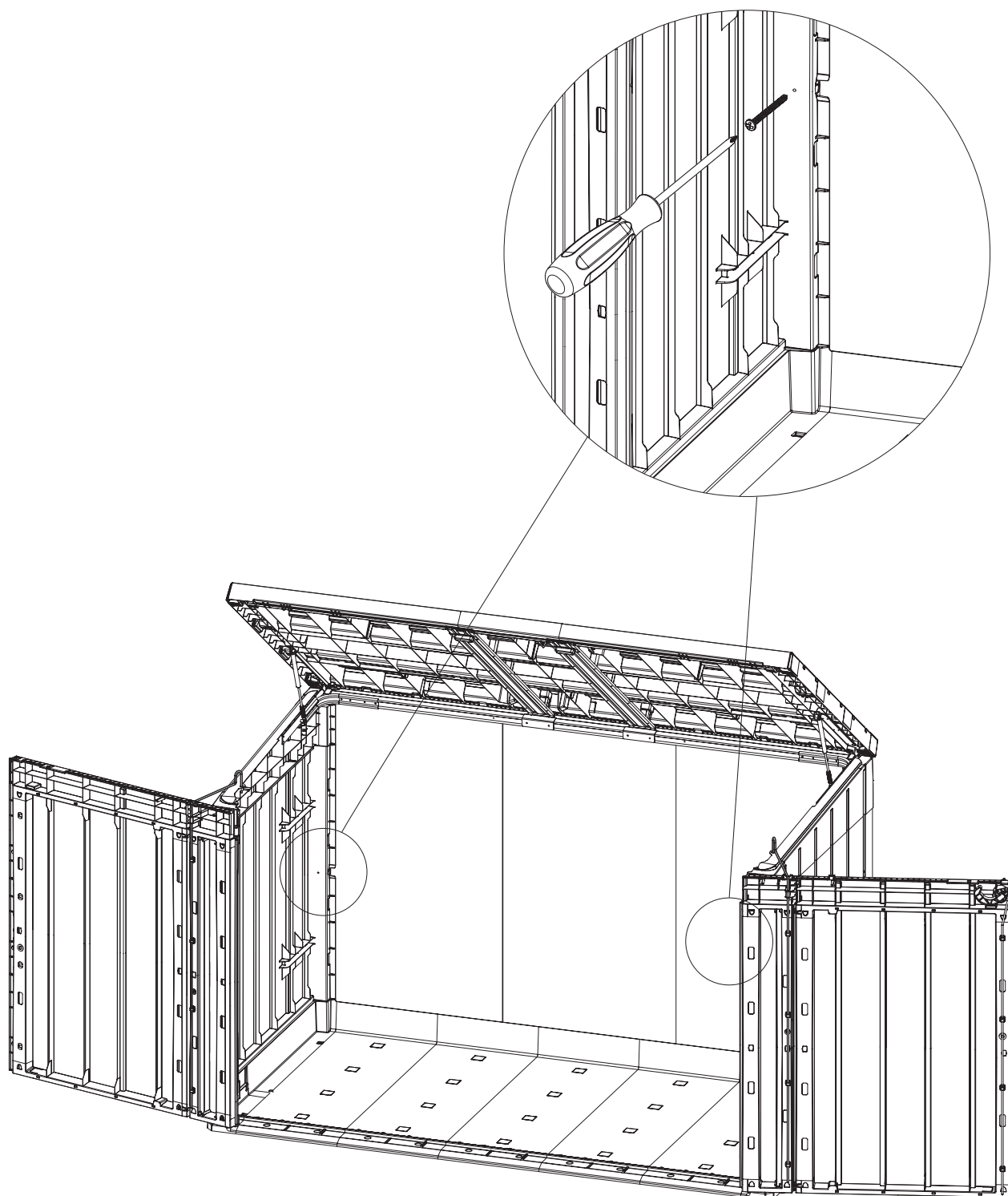

2x M4



2x Ø 6 mm

OPZIONE 3 / OPTION 3

IT: Fissaggio a terra **EN: Ground fixing**

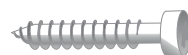
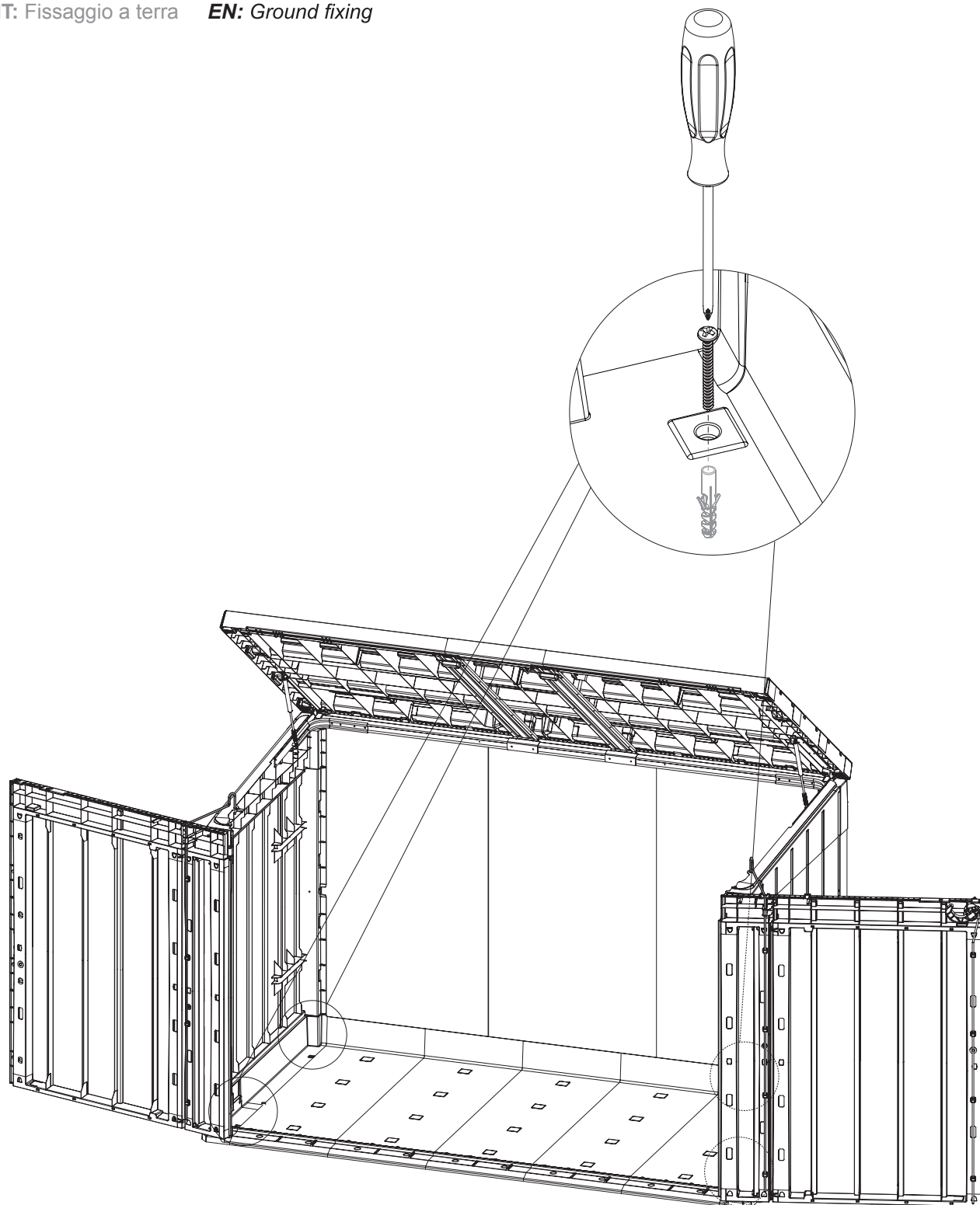

4x M4



4x Ø 6 mm

OPZIONE 4 / OPTION 4

IT: Opzionalmente è possibile acquistare una tavola di legno da utilizzare come mensola

EN: It is possible to purchase, as an option, a wooden plank and use it as a shelf

IT: Dimensioni consigliate **EN:** Suggested dimensions

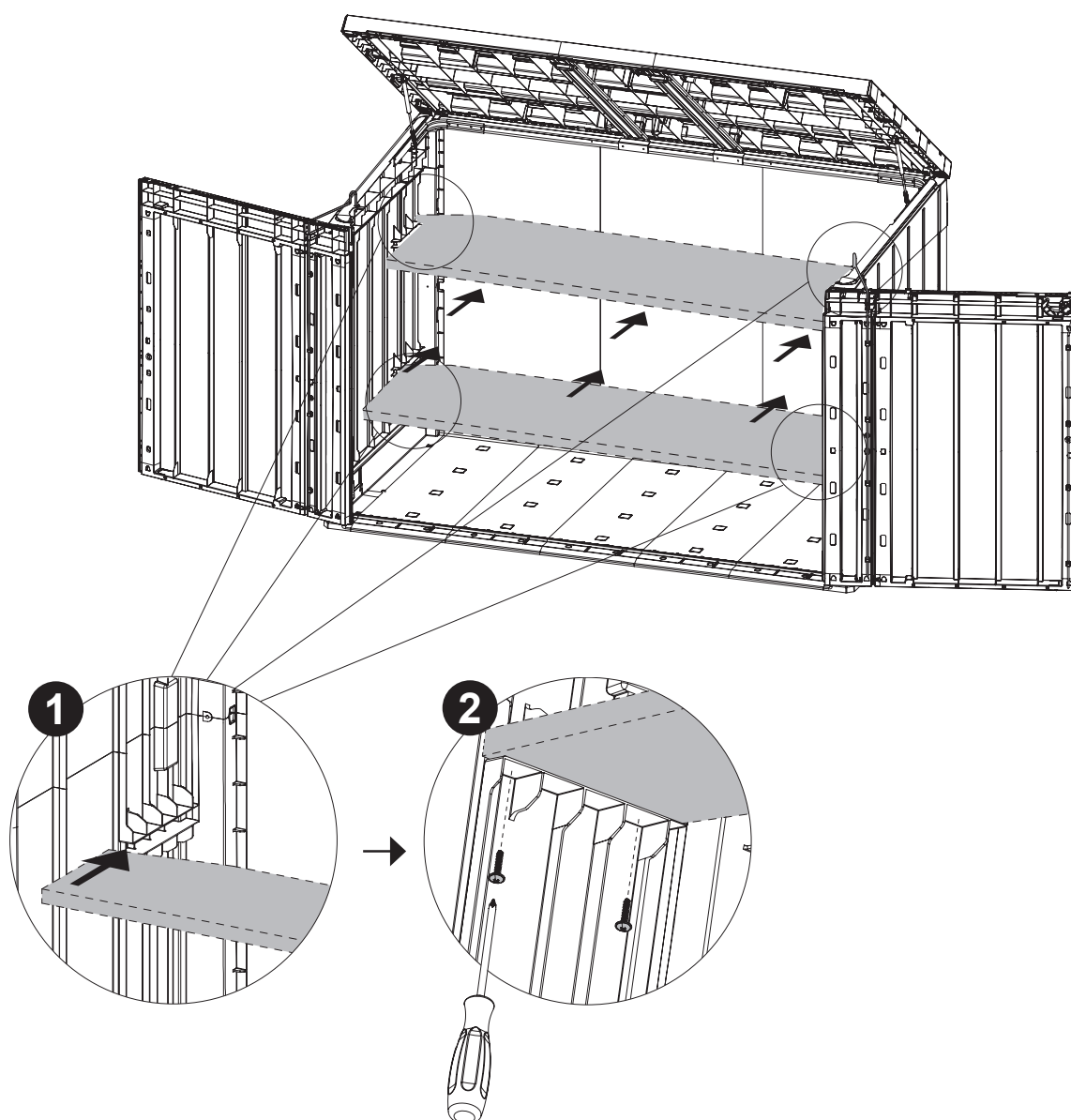
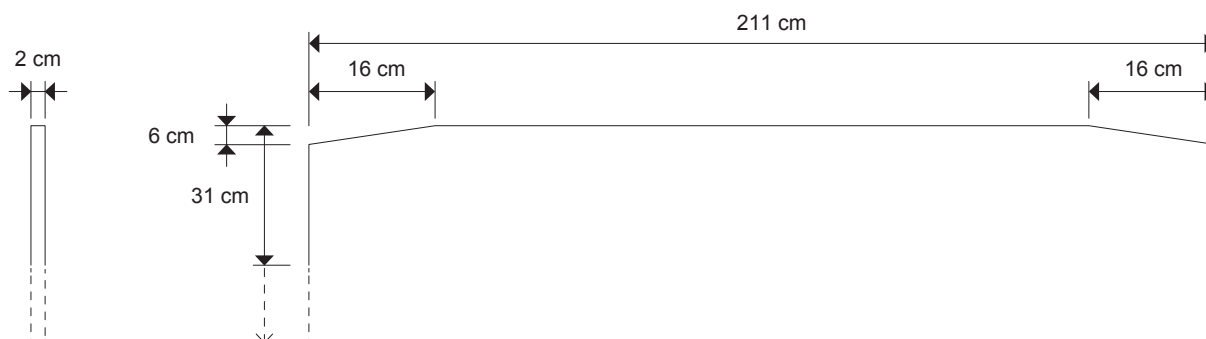



Plastmeccanica S.p.A.

Viale del Lavoro, 3

60030 Castelfellino (An) - ITALY

Tel. +39 0731 70766 - Fax +39 0731 703796

info@plastmeccanica.it



www.toomax.it